

# 4U100 Series

## User Manual

Version 1.0

Published June 2018

Copyright©2018 ASRock Rack INC. All rights reserved.

Version 1.0

Published June 2018

Copyright©2018 All rights reserved.

## Copyright Notice:

No part of this documentation may be reproduced, transcribed, transmitted, or translated in any language, in any form or by any means, except duplication of documentation by the purchaser for backup purpose, without written consent of us.

Products and corporate names appearing in this documentation may or may not be registered trademarks or copyrights of their respective companies, and are used only for identification or explanation and to the owners' benefit, without intent to infringe.

## Disclaimer:

Specifications and information contained in this documentation are furnished for informational use only and subject to change without notice, and should not be construed as a commitment by us. We assume no responsibility for any errors or omissions that may appear in this documentation.

With respect to the contents of this documentation, we do not provide warranty of any kind, either expressed or implied, including but not limited to the implied warranties or conditions of merchantability or fitness for a particular purpose.

In no event shall we, our directors, officers, employees, or agents be liable for any indirect, special, incidental, or consequential damages (including damages for loss of profits, loss of business, loss of data, interruption of business and the like), even if we have been advised of the possibility of such damages arising from any defect or error in the documentation or product.



This device complies with Part 15 of the FCC Rules. Operation is subject to the following two conditions:

- (1) this device may not cause harmful interference, and
- (2) this device must accept any interference received, including interference that may cause undesired operation.

## CALIFORNIA, USA ONLY

The Lithium battery adopted on this motherboard contains Perchlorate, a toxic substance controlled in Perchlorate Best Management Practices (BMP) regulations passed by the California Legislature. When you discard the Lithium battery in California, USA, please follow the related regulations in advance.

“Perchlorate Material-special handling may apply, see [www.dtsc.ca.gov/hazardouswaste/perchlorate](http://www.dtsc.ca.gov/hazardouswaste/perchlorate)”

## Important Safety Instructions

Pay close attention to the following safety instructions before performing any of the operation. Basic safety precautions should be followed to protect yourself from harm and the product from damage:

- Operation of the product should be carried out by suitably trained, qualified, and certified personnel only to avoid risk of injury from electrical shock or energy hazard.
- Disconnect the power cord from the wall outlet when installing or removing main system components, such as the motherboard and power supply unit.
- Place the system on a stable and flat surface.
- Use extreme caution when working with high-voltage components.
- When handling parts, use a grounded wrist strap designed to prevent static discharge.
- Keep the area around the system clean and clutter-free.
- Keep all components and printed circuit boards (PCBs) in their antistatic bags when not in use.
- Handle a board by its edges only; do not touch its components, peripheral chips, memory modules or contacts.

## **Contents**

<b>Chapter 1 Introduction</b>	<b>1</b>
1.1 System Package Contents	2
1.2 Specifications	4
<b>Chapter 2 Server System Overview</b>	<b>5</b>
2.1 System Components	6
2.2 Board Arrangement	8
2.3 System Front Panel	9
2.4 System Rear Panel	9
2.5 Front Control Panel Buttons and LEDs	11
<b>Chapter 3 Hardware Installation and Maintenance</b>	<b>13</b>
3.1 Server Top Cover	14
3.2 Hard Drive	16
3.2.1 Installing OS Drives into 2.5" Hard Drive Trays	16
3.2.2 Installing a 3.5" Hard Disk Drive into the Hard Drive Tray	18
3.3 Power Supply	20
3.4 Add-on Card	22
3.5 LAN Mezzanine Card	24
3.6 System Fan	27
3.7 Motherboard	29
<b>Appendix A</b>	<b>32</b>
Installing the CPU	32
Installing the CPU Fan and Heatsink	35
Installation of Memory Modules (DIMM)	36

**Appendix B**

**37**

Slide Rail Operation

37

# Chapter 1 Introduction

Thank you for purchasing ASRock Rack 4U100 Series, a reliable barebone system produced under ASRockRack's consistently stringent quality control. It delivers excellent performance with robust design conforming to ASRockRack's commitment to quality and endurance.



*Because the hardware specifications might be updated, the content of this documentation will be subject to change without notice. In case any modifications of this documentation occur, the updated version will be available on ASRockRack's website without further notice. If you require technical support related to this product, please visit our website for specific information about the model you are using.  
ASRockRack's Website: [www.ASRockRack.com](http://www.ASRockRack.com)*



*The illustrations shown in this manual are examples only, the actual system may differ slightly.*

## 1.1 System Package Contents

Item	Length(mm)	Quantity
4U100 Series Barebone (4U form factor)	-	1
BP Power Cable	450	2
Fan Cable	120	8
Mid Board to Rear IO	700	1
Mid Board to LED Board	400	1
Mid Board to SW Board	400	1
Mid Board to OS BP	200	1
Mid Board to LCM	400	1
Mid Board to USB2.0	360	1
Mid Board Power Cable	460	1
OS BP Power Cable	200	1
Mid Board to PDB	530	1
MB Signal Cable	650	1
MB Signal Cable	330	1
MB Signal Cable	450	1
BP Power Cable	940	2
MiniSAS HD Cable (with sideband)	450	4
MiniSAS HD Cable (with sideband)	920	1
MiniSAS HD Cable (with sideband)	750	1
MiniSAS HD Cable	460	1
MiniSAS HD Cable	560	1
SATA Cable	180	2
SATA Cable	500	2
2000W PSU	-	2
CPU Heatsink (CPU1)	-	1
CPU Heatsink (CPU2)	-	1
FAN - Real 8038	-	4
FAN - Front 8038	-	4
FAN - MCU 4056	-	6
Riser Card	-	2
Cable Management Arm (CMA)	-	1

Item	Length(mm)	Quantity
Rail	-	1
Power Cord	-	2



*If any items are missing or appear damaged, contact your authorized dealer.*



## 1.2 Specifications

4U100 Series	
System Physical Status	
Form Factor	4U Rackmount
Dimension (D x W x H)	<ul style="list-style-type: none"> <li>• 1000mm(D)x447mm(W)x175mm(H) (39.4”(D)x17.6”(W) x6.89”(H))</li> <li>(Lower case width=435mm for rail installation)</li> </ul>
Support MB Size	Half Width, 18.6”X6.5”
Front Panel	
Buttons	<ul style="list-style-type: none"> <li>• 1 x Power On/Off button</li> <li>• 1 x ID button</li> <li>• 1 x LCM</li> </ul>
LEDs	<ul style="list-style-type: none"> <li>• 1 x Power On/Off button</li> <li>• 1 x ID button</li> <li>• 1 x LCM</li> </ul>
I/O Port	1 x USB 2.0 port
Drive Bay	
Internal	<ul style="list-style-type: none"> <li>• 100 x 3.5” Hot-swap SATA HDD or SAS HDD</li> <li>• 2 x 2.5” Hot-swap SATA HDD</li> </ul>
System Cooling	
Fan (Front)	4 x 8038 system fans
Fan (Rear)	4 x 8038 system fans
Fan (MCU)	4 x 4056 system fans
Power Supply	
Capacity	2 (1+1) Redundant
Output Watts	2000W
Efficiency	Platinum



Please refer to the user manual of the motherboard for detailed information about motherboard components and features.

## Chapter 2 Server System Overview

This chapter provides diagrams showing the location of important components of the server system.

4U100 Series:

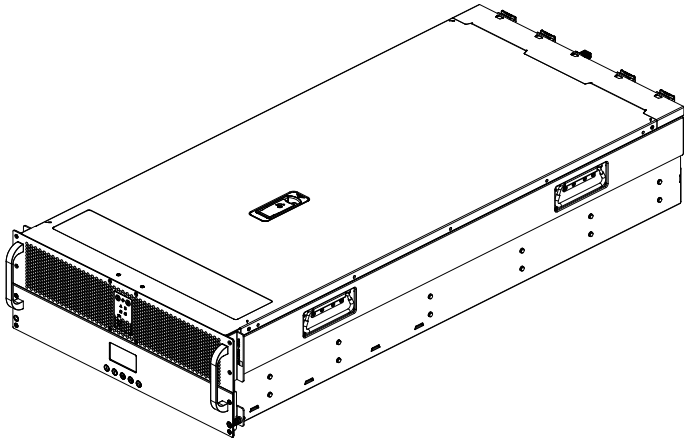

## 2.1 System Components

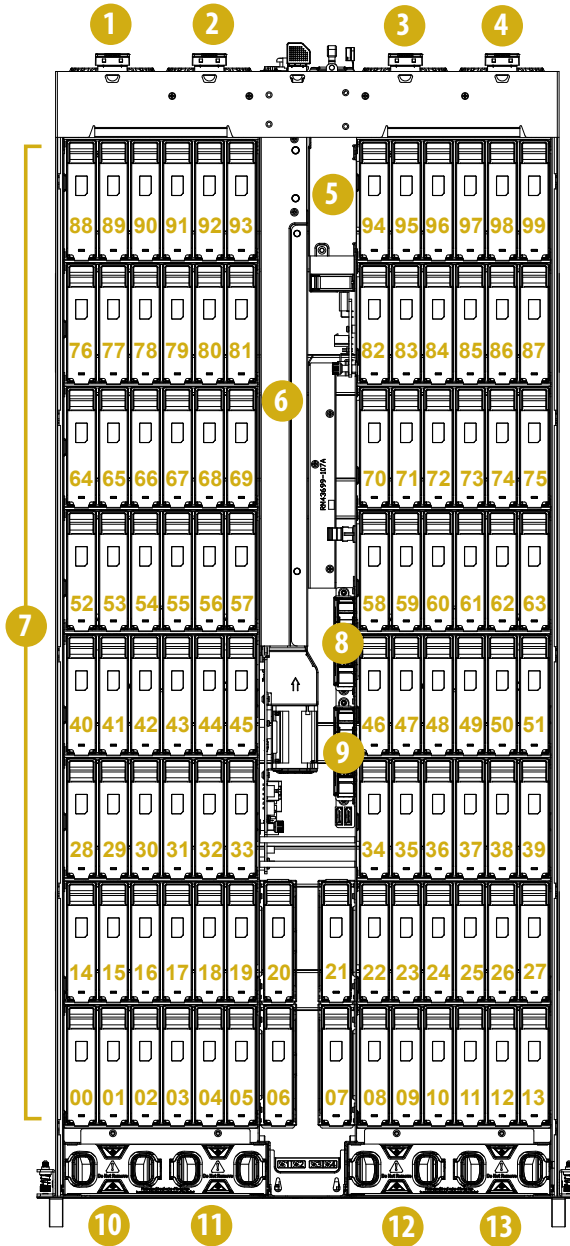

No.	Item
1	Rear System Fan (Fan5)
2	Rear System Fan (Fan6)
3	Rear System Fan (Fan7)
4	Rear System Fan (Fan8)
5	2 x Power Supply Units
6	Motherboard Tray
7	100 x 3.5" or 2.5" Hot-Swap SATA/SAS HDD Trays (HDD0~HDD99)
8	2.5" SSD Tray
9	2.5" SSD Tray
10	Front System Fan (Fan1)
11	Front System Fan (Fan2)
12	Front System Fan (Fan3)
13	Front System Fan (Fan4)

## 2.2 Board Arrangement

No.	Item
1	EP2C612D8HM
2	Rear Expander 24bay BP
3	Front Expander 24bay BP
4	Middle plane BP
5	PDB
6	LED board
7	2port 2.5" OS BP
8	Switch board (front)
9	HDD BP-top daughter board
10	HDD BP-down daughter board
11	Interposer BP
12	Riser Card (L)
13	Riser Card (R)
14	Riser Card

## 2.3 System Front Panel

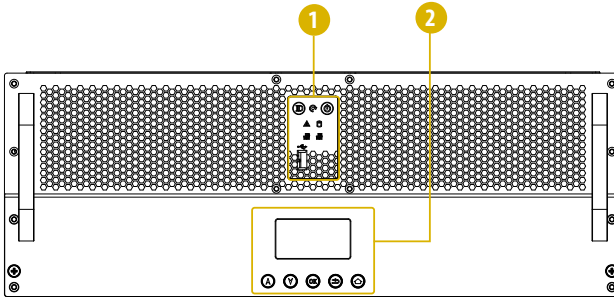

No.	Item
1	Control Panel Buttons and LEDs
2	LCD Panel and Buttons

## 2.4 System Rear Panel

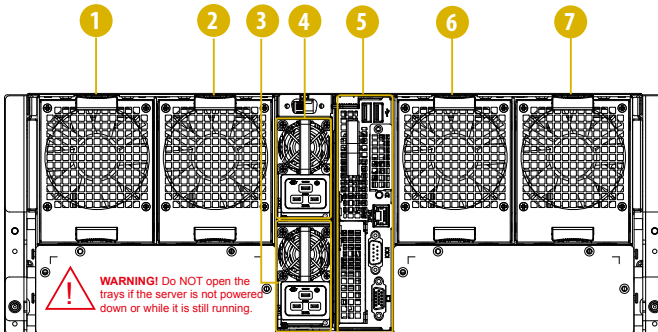

No.	Item
1	Rear System Fan (FAN8)
2	Rear System Fan (FAN7)
3	Power Supply Unit (PSU0)
4	Power Supply Unit (PSU1)
5	Motherboard Tray
6	Rear System Fan (FAN6)
7	Rear System Fan (FA58)

## Motherboard Tray

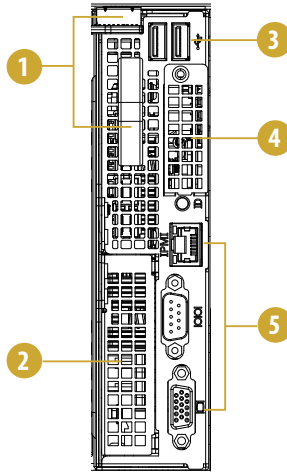

No.	Item
1	Motherboard Tray Handles
2	Add-on Card Slot
3	USB 3.0 Ports
4	Mezzanine Card Slot (only supports M350R/ M540R / M599R)
5	I/O Panel

## 2.5 Front Control Panel Buttons and LEDs

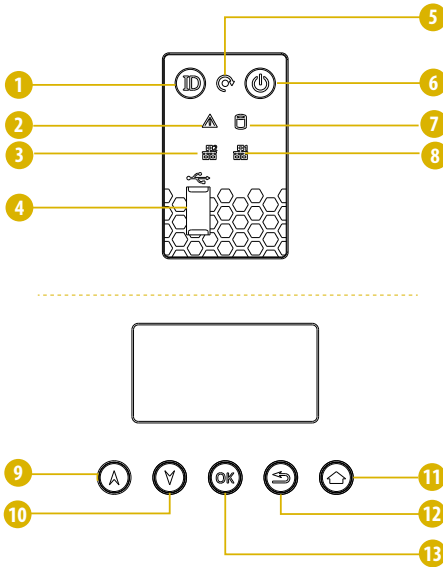

No.	Item
1	Identify LED Button
2	Global Failure Indicator (PSU fault/Fan error/High temperature)
3	LAN2 Activity LED
4	USB 2.0 Port
5	Reset Button
6	Power LED Button
7	HDD Activity LED
8	LAN1 Activity LED
9	Up Button
10	Down Button
11	Home Button
12	Back Button
13	OK Button



## Power Button

Press the power switch button to toggle the system power on and off.

To remove all power from the system completely, disconnect the power cord from the server.

## ID Button

Press the ID button to toggle the front panel ID LED and the baseboard ID LED on and off. You are able to locate the server you're working on from behind a rack of servers.

## System Reset Button

When the system is completely unresponsive, press the system reset button to reboot the server without shutting it off and initialize the system.

## Status LED Definitions

Power LED	
Status	Description
Green	Power on
Off	Power off

ID LED	
Status	Description
Blue	System identification is active.
Off	System identification is disabled.

LAN1, LAN2 LEDs	
Status	Description
Green	Link between system and network or no access
Blinking Green	Network access

HDD Activity LED	
Status	Description
Blinking Green	HDD access
Off	HDD idle

Global Failure Indicator / System Event LED	
Status	Description
Off	Running or normal operation
Red	At least one sensor has critical alert

## Chapter 3 Hardware Installation and Maintenance

This chapter helps you assemble the chassis and install components.

### Before You Begin

Before you work with the server, pay close attention to the “Important Safety Instructions” at the beginning of this manual.

1. Make sure the server is powered off.

Power down the server if it is still running.

- (1) Press the Power button to power off the server from full-power mode to power-off mode. The Power LED at the front turns from solid green to off.
- (2) Disconnect the power cord first from the AC outlet and then from the server. The power LED turns off.



*The server is not completely powered down when you press the Power button on the front panel. Some internal circuitry remain active in the Power-off mode. To remove all power from the system completely, be sure to disconnect the power cord from the server.*

2. Ensure you have a clean and stable working environment. Avoid dust and dirt because contaminants may cause malfunctions.
3. Ground yourself properly before touching any system component. A discharge of static electricity may damage components. Wear a grounded wrist strap if available.



*After all components are well installed, then you can connect the power cord to the AC outlet and then press the Power button to power on the server.*

## 3.1 Server Top Cover

### Removing the Server Top Cover



1. Before removing the top covers, power off the server and unplug the power cord.
2. The system must be operated with all the chassis top covers installed to ensure proper cooling.

1. Push the cover latch button to release the latch handle.
2. Remove the eight screws that secure the top cover to the chassis.
3. Lift the chassis top cover off the chassis.

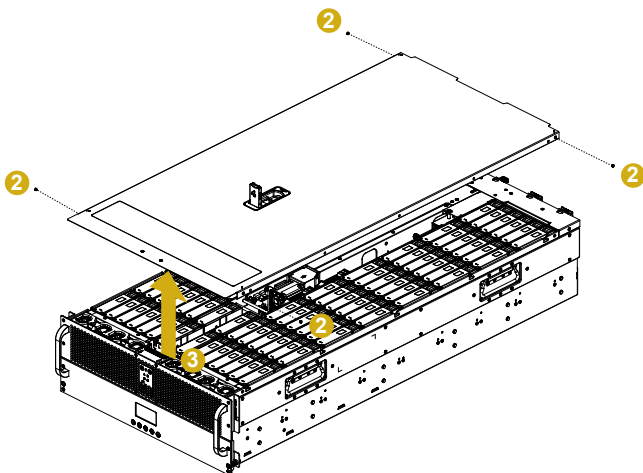
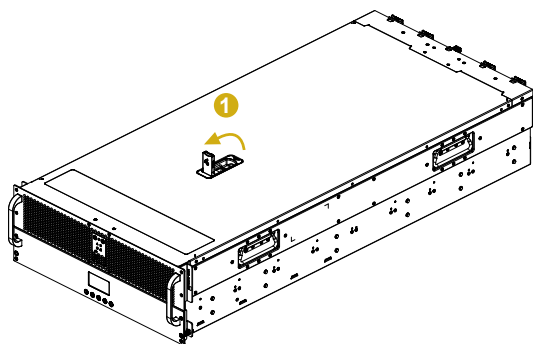

## Installing the Server Top Cover

1. Lower the top cover on the chassis, with the latch handle open.
2. Secure the top cover with the screws.
3. Close the latch handle.

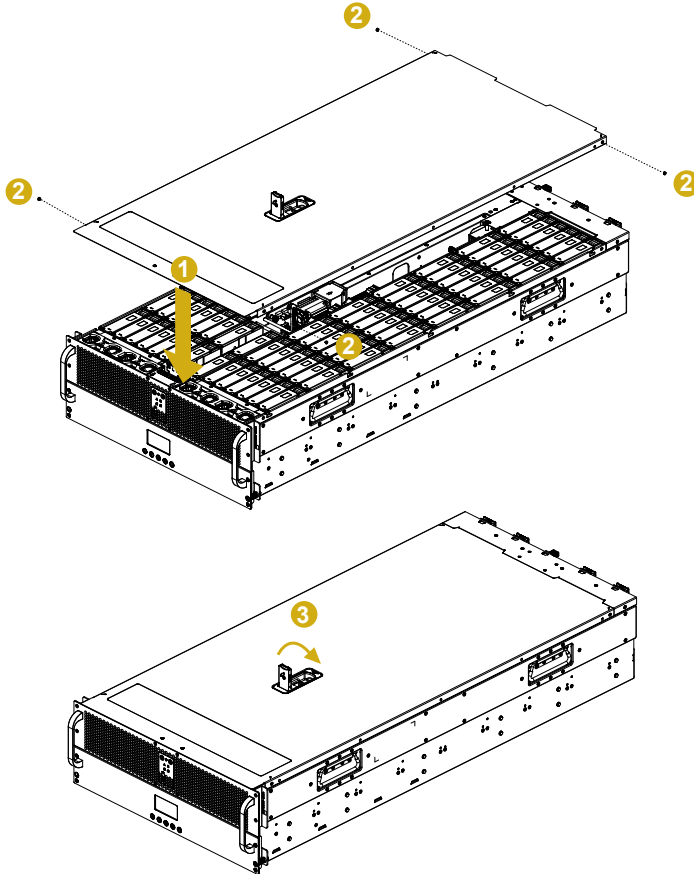

## 3.2 Hard Drive

### 3.2.1 Installing OS Drives into 2.5" Hard Drive Trays

#### Removing 2.5" Hard Drive Trays from the Chassis

1. Press the locking lever latch on the drive tray to unlock the retention lever.
2. Rotate the lever out and away from the module bay and pull the hard drive out of the HDD tray.

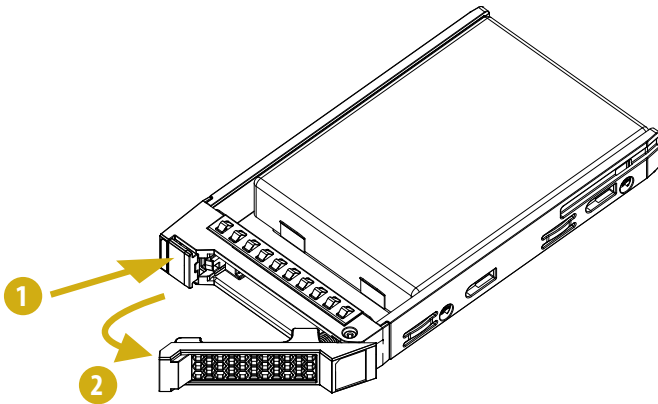

## Installing a 2.5" OS Drive to the Hard Drive Tray

1. Place a 2.5" OS drive into the tray with the printed circuit board side facing down. Carefully align the mounting holes in the hard drive and the tray.
2. Secure the hard drive using the two screws.
3. Slide the drive tray into the HDD bay until the drive is fully seated.
4. Push in the locking lever to lock the HDD tray into place.

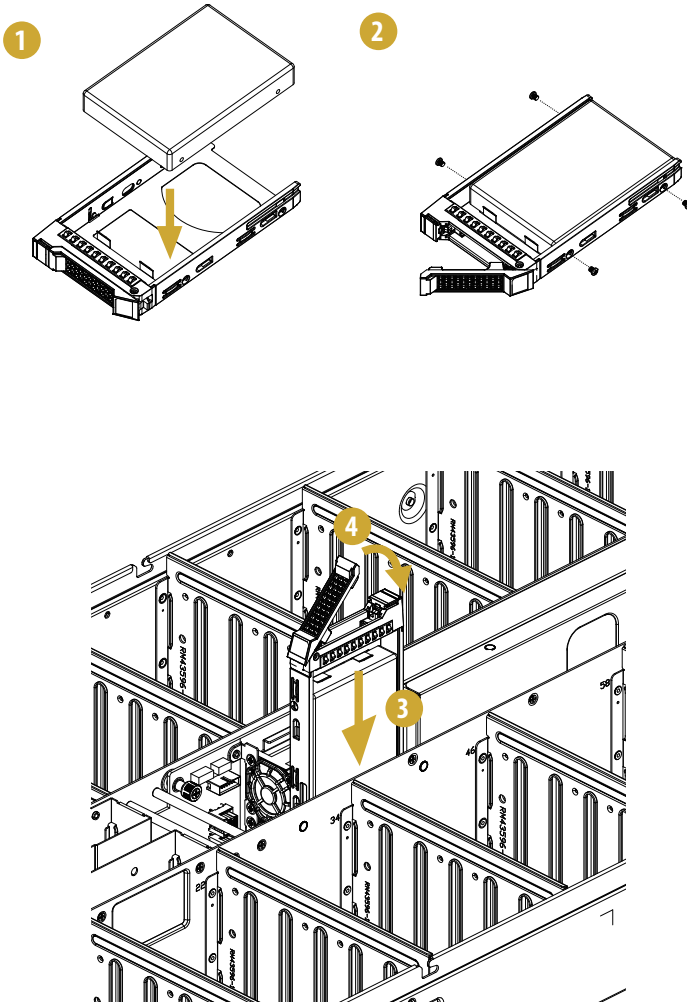

### 3.2.2 Installing a 3.5" Hard Disk Drive into the Hard Drive Tray

#### Removing a Hard Drive Tray from the Chassis

1. Press the locking lever latch on the drive tray to unlock the retention lever.
2. Rotate the lever out and away from the module bay.
3. Pull the hard drive tray out of the chassis.

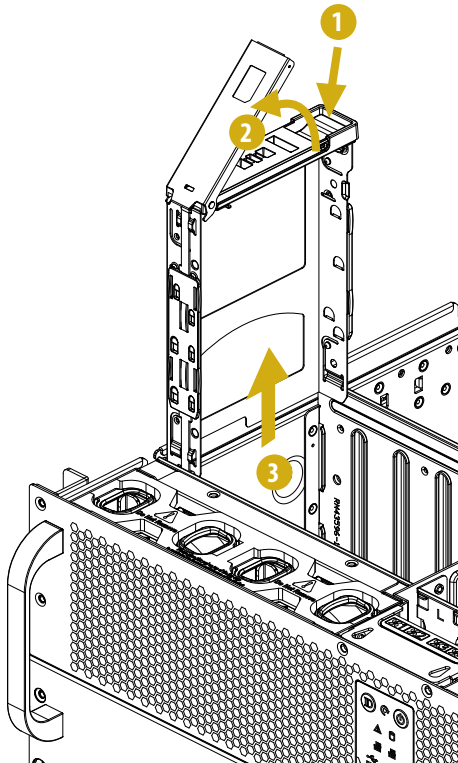

## Installing a 3.5" Hard Drive into the Chassis

1. Carefully align and place the hard drive into the tray.
2. Gently slide the HDD tray into the chassis evenly.
3. Push the tray downwards until it is firmly seated and locks into place.

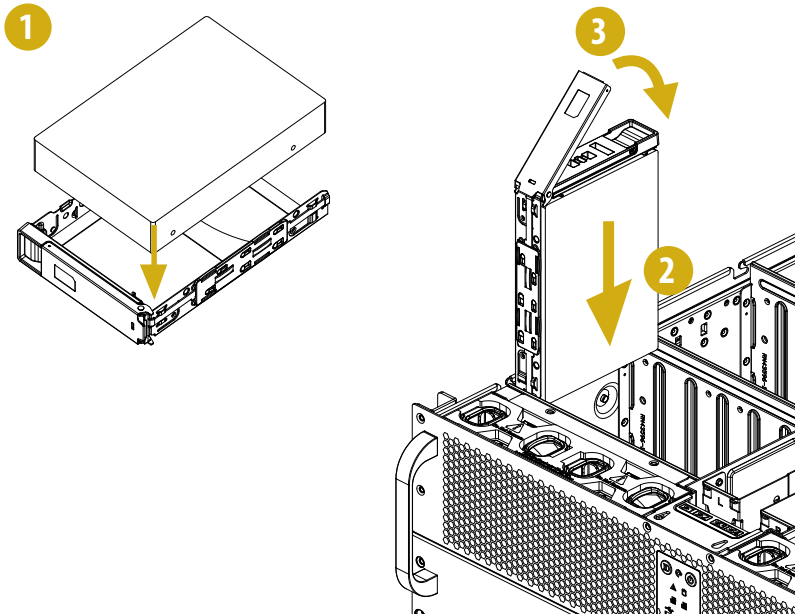



### 3.3 Power Supply

The 4U100 Series can accommodate two CRPS (Common Redundant Power Supplies) power supplies in the bay at the rear of the chassis. Each unit provides up to 2000 Watts of power. Three power supplies are required for operation, with the other power supply purely as a redundant, load-sharing backup. It can be removed without affecting system operation.



*Before replacing the power supply, power off the server, unplug the power cord, and disconnect all wiring from the power supply.*

#### Installing and Removing the Power Supply

##### Installing the Power Supply Unit

1. Align the power supply unit with the power supply slot. Ensure that the LED appears on the lower right when you are installing the power supply unit.
2. Carefully slide the PSU all the way into the power supply bay until it clicks into place.

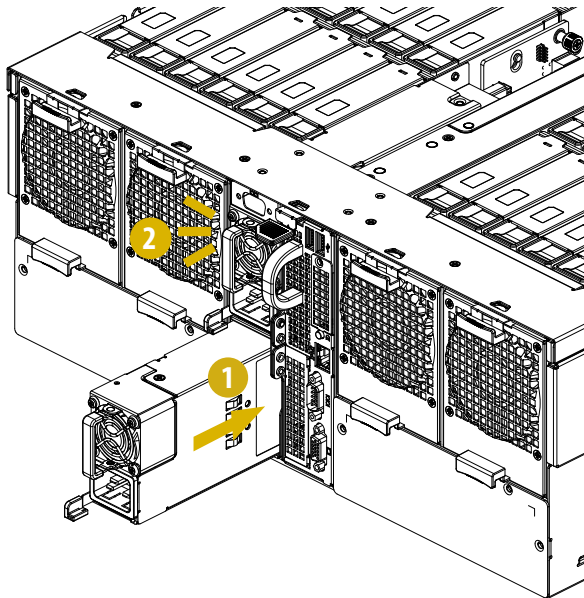

## Removing the Power Supply Unit

To remove a failed power supply, identify the failed power supply by checking the power supply LEDs on the PSU.

1. Hold onto the power supply handle while pressing the locking lever towards the power supply handle.
2. Pull to remove the power supply from the chassis.

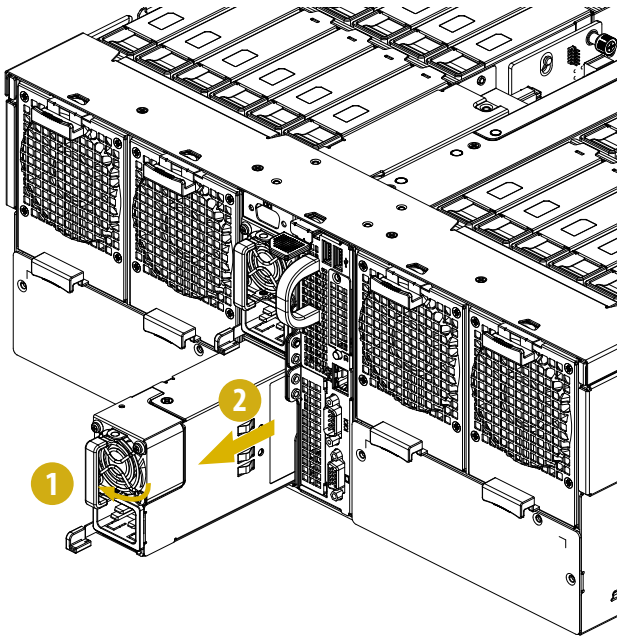

1. Before replacing the power supply, power off the server, unplug the power cord, and disconnect all wiring from the power supply.
2. In a redundant system, you do not need to power down the server.

### 3.4 Add-on Card



Before installing the add-on card, power off the server and unplug the power cord.

#### Installing the Add-on Card in the Chassis

Please remove the motherboard tray before the following installation. Refer to the section entitled "Motherboard Tray" for more instructions.

1. Release the screws securing the cover to the motherboard tray.
2. Slide the cover toward the rear of the tray. Then, lift the cover off the tray.
3. Release the screws securing the two riser card assemblies.
4. Remove the left riser card assembly first and then the other one.

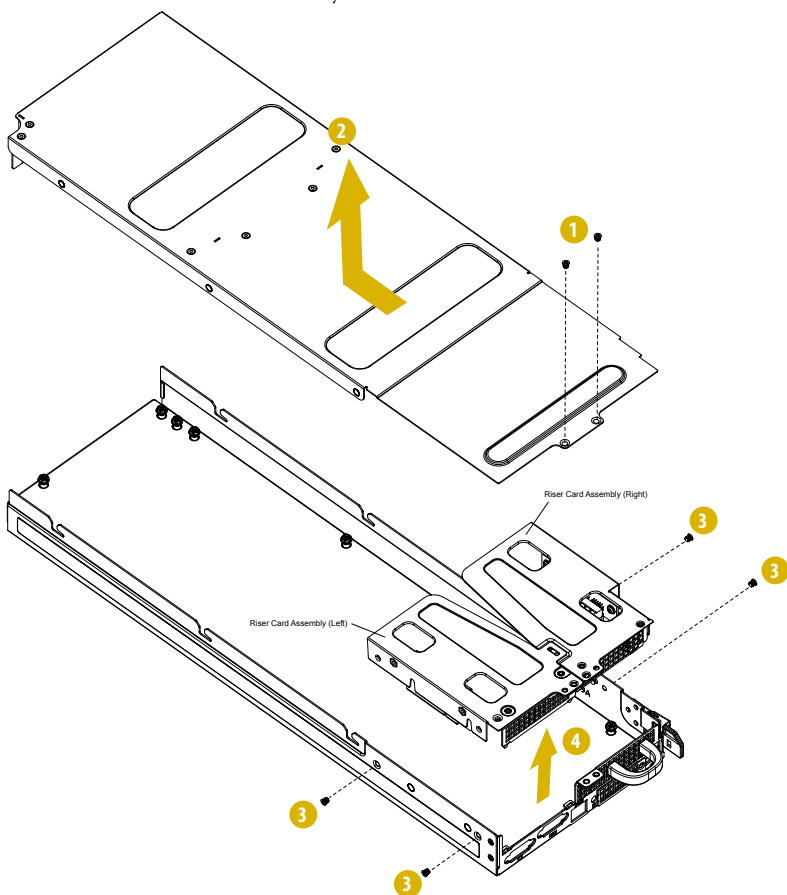

5. Install the add-on card to the riser-card assembly. Make sure the add-on card is well and firmly installed into the connector of the riser card on the assembly.
6. Attach the matching I/O plate to the LAN card and secure it with the screw.

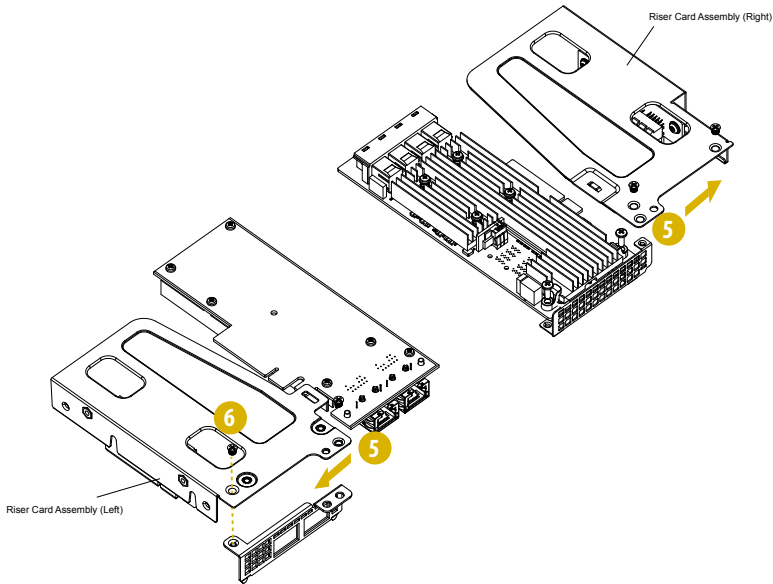

7. Be sure to install the right riser-card assembly into the chassis first.
8. Then install the left one.
9. Use the screws, you set aside in Step 3, to secure both assemblies.
10. Replace the cover back and secure it with screws.

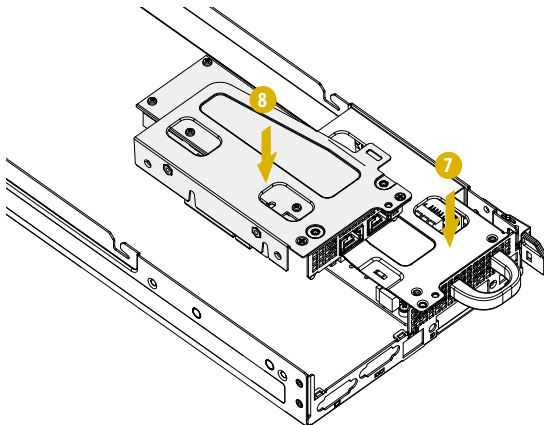

---

## 3.5 LAN Mezzanine Card

Before installing a mezzanine card, you need to remove the add-on card and the riser-card assembly first. To know more about how to remove the riser-card assembly, please see the section entitled "3.4 Add-on Card".

### Removing the Blanking Plate for a LAN Mezzanine Card

Remove the screws that secure the blanking plate on the chassis. Keep the screws for later use.

## Installing a LAN Mezzanine Card

You can use an optional Ethernet mezzanine card for additional LAN ports. Please be aware that the mezzanine card must be used in conjunction with a matching I/O module.

1. Install the four spacer supports into the motherboard around the mezzanine card slot.
2. Gently insert the mezzanine card into the mezzanine card slot on the motherboard.

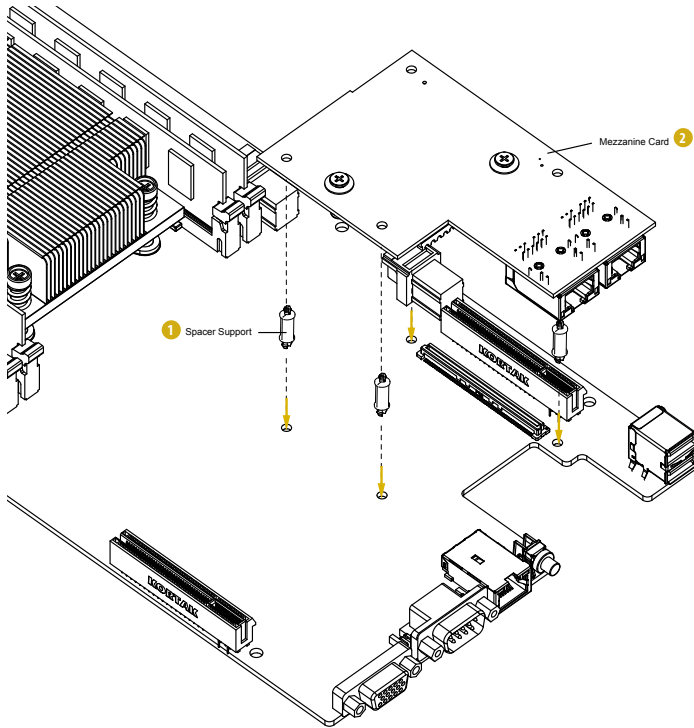

- 
3. Tighten the screws to secure the matching I/O module to the chassis.

## 3.6 System Fan

The 4U100 series chassis supports hot-swappable system fans.

### Replacing the System Fan

Before replacing the system fan, remove the top cover from the chassis. (See p. 14 for more details.)

#### Front Fan Module

1. Remove the aero pad on the fans.
2. Grasp and pull the system fans out of the chassis.

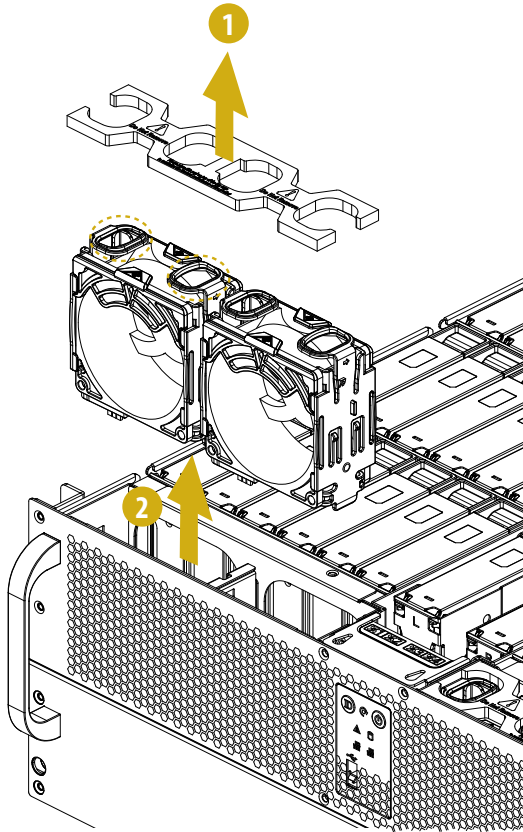



## Rear Fan Module

1. Press and hold the clip on the rear fan
2. Pull to remove the system fan away from the chassis.

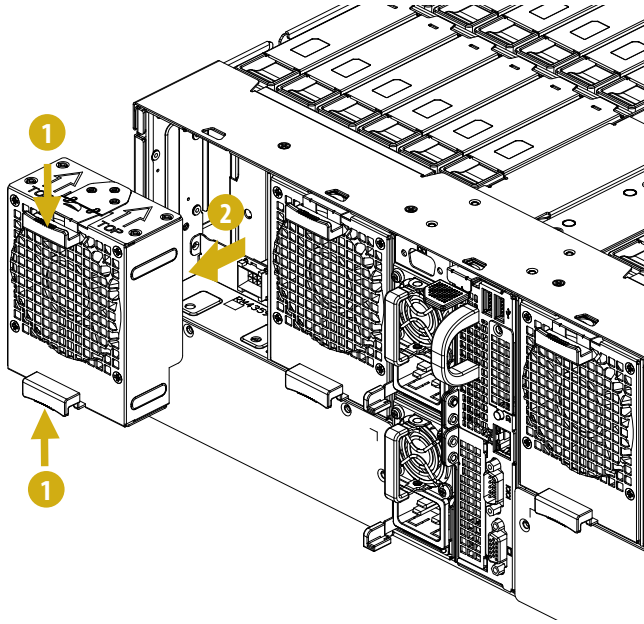

## 3.7 Motherboard



*Attention! DO NOT open the motherboard tray if the server is not powered down or while it is still running.*

### Replacing the Motherboard

You must remove all connected cables from the motherboard to avoid damaging the motherboard and its components when you remove it later.

1. Press the lever toward the handle and pull out the motherboard tray.

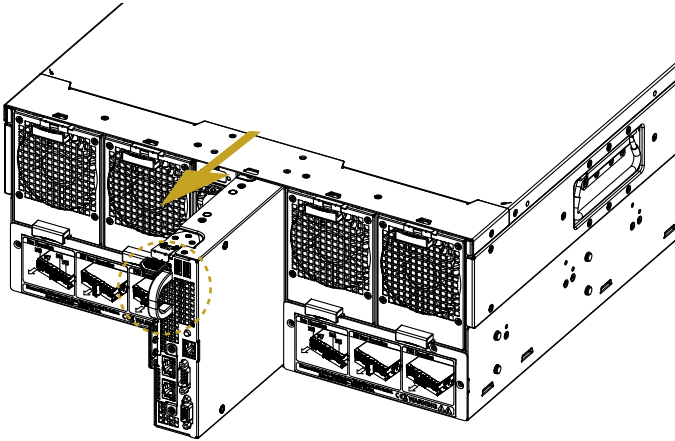

2. Loosen the screws to remove the tray cover and the riser-card bracket.

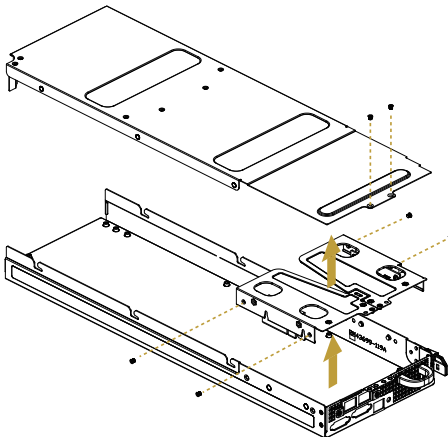

3. Gently place the motherboard into the chassis. Align mounting holes of the motherboard to the standoff on the chassis. Affix the screws clockwise into the mounting holes in all of the corners of the motherboard.

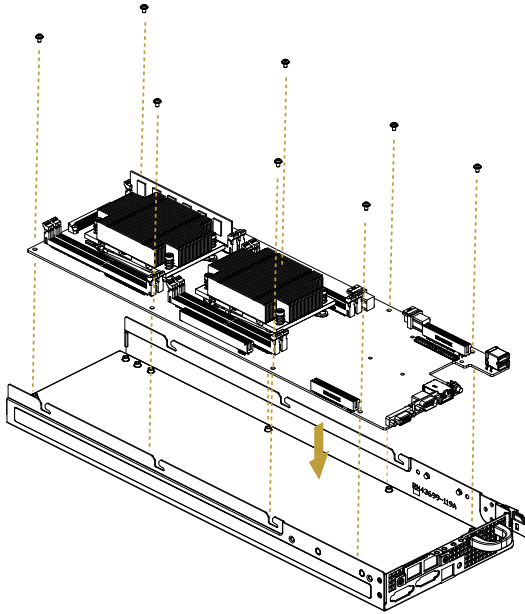

4. Put the tray cover and the bracket back and secure them with screws.

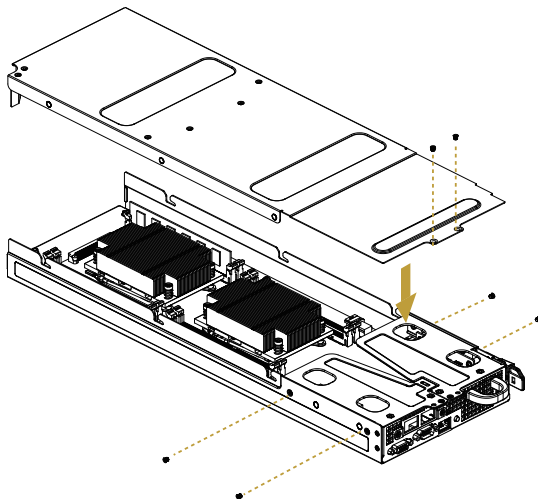

- Carefully slide the motherboard tray all the way into the bay until it clicks into place.

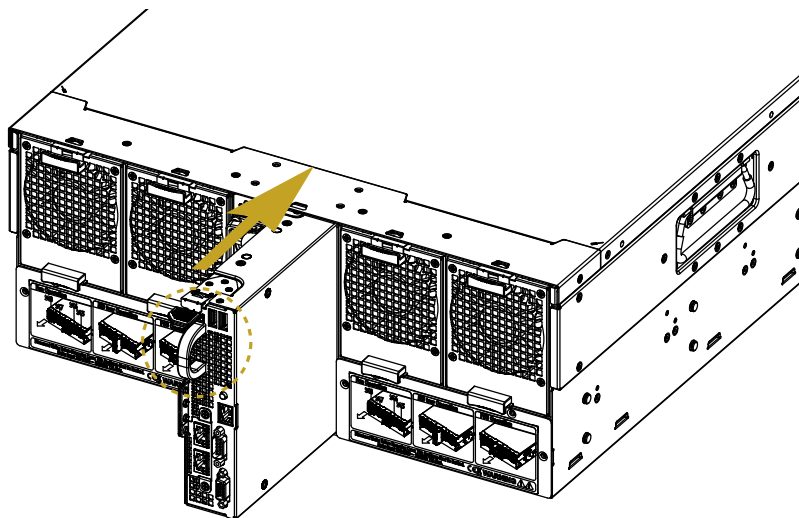

# Appendix A

## Installing the CPU



1. Before you insert the 2011-3-Pin CPU into the socket, please check if the PnP cap is on the socket, if the CPU surface is unclean, or if there are any bent pins in the socket. Do not force to insert the CPU into the socket if above situation is found. Otherwise, the CPU will be seriously damaged.
2. Unplug all power cables before installing the CPU.

### CAUTION:

Please note that C612 platform is only compatible with the LGA 2011-3 socket, which is incompatible with the LGA 2011 socket

**Socket Type: Narrow ILM Socket**

1

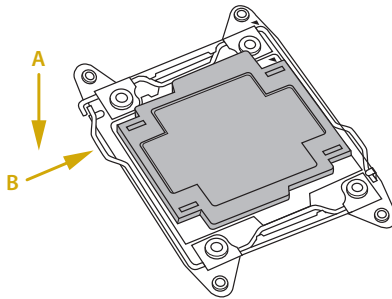

2

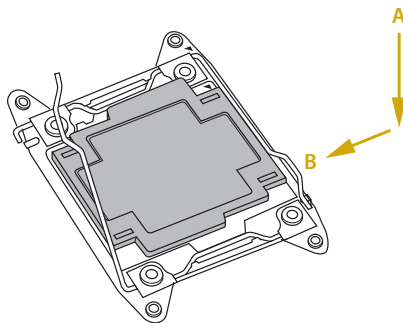

3

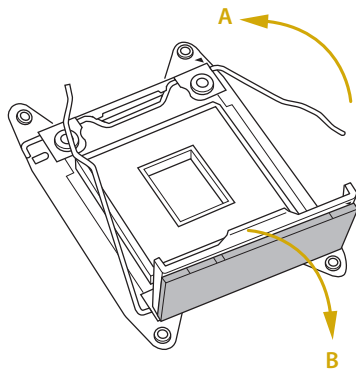

4

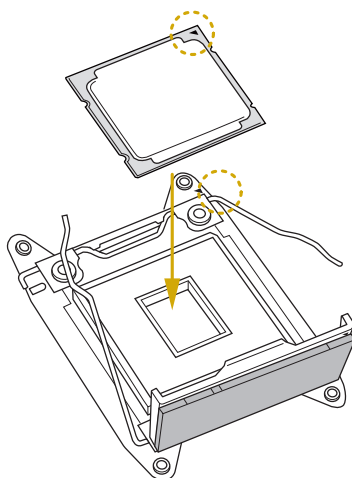

5

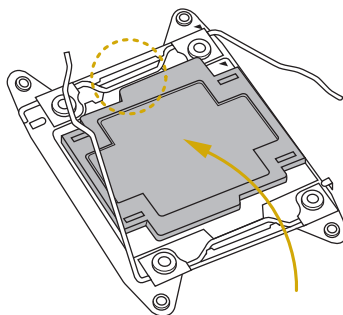

6

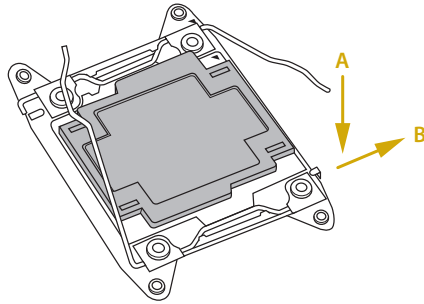

7

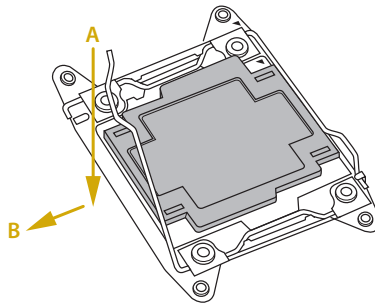

8

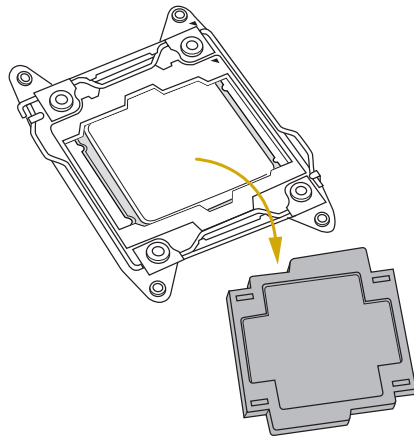

*The cover must be placed if returning the motherboard for after service.*

## Installing the CPU Fan and Heatsink

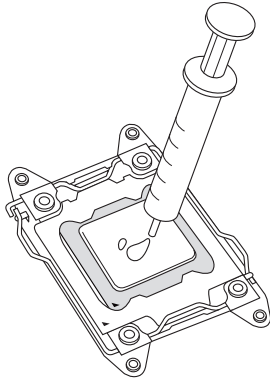
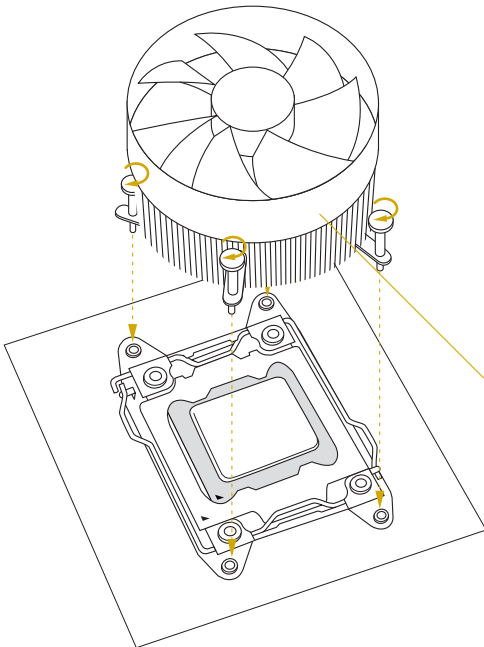
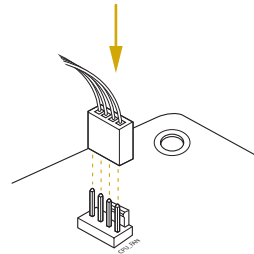

Before you installed the heatsink, you need to spray thermal interface material between the CPU and the heatsink to improve heat dissipation.

**1****2**

CPU fan for narrow 4-pin socket  
\*Support an active or passive heatsink



## Installation of Memory Modules (DIMM)



The DIMM only fits in one correct orientation. It will cause permanent damage to the motherboard and the DIMM if you force the DIMM into the slot at incorrect orientation. For more information about DIMM installation, please refer to the User Manual that comes with the serverboard you use.

1

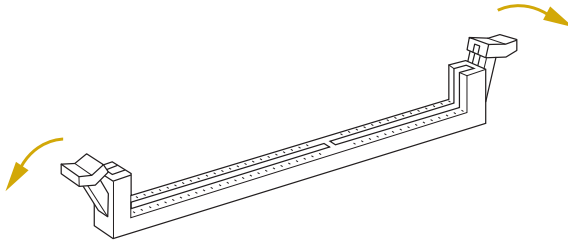

2

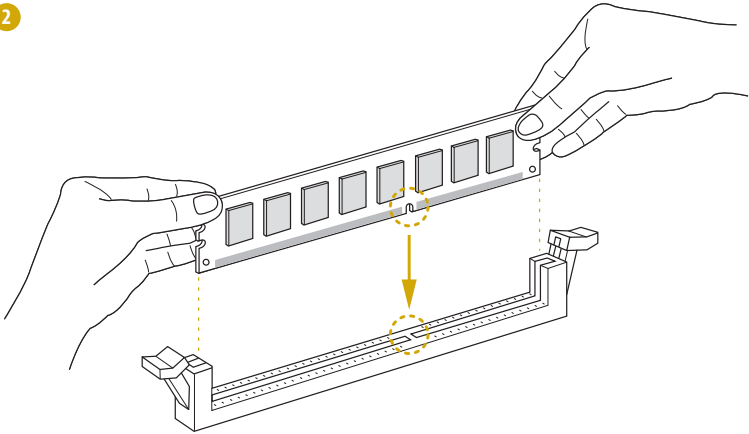

3

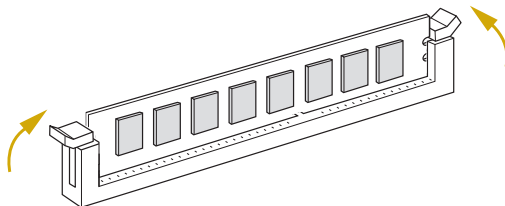

## Appendix B

### Slide Rail Operation

1. Pull out the chassis fully extended to lock position.

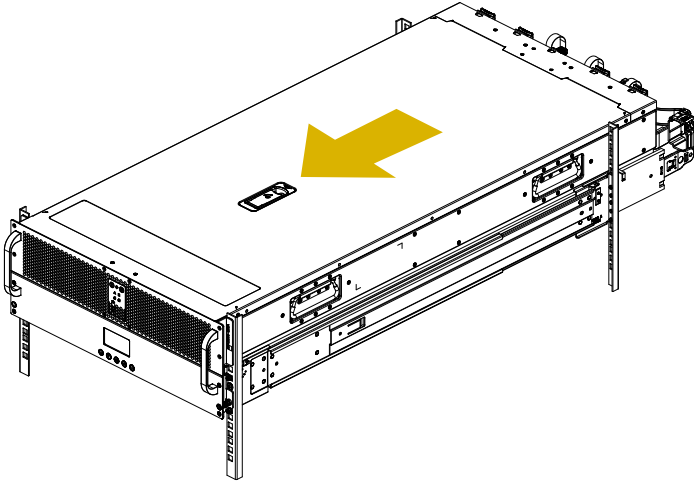

2. Push the chassis all the way back into the rack.

