



OPEN

Industry Standard, Flexible Architecture

GREEN

Less Heat, Less Power Consumption

STABLE

Robust Design, Quality Parts

Stable and  
Reliable Solution

Server/Workstation

Motherboard

# GENOAD12M3-2Q

## User Manual

English



Version 1.0

Published July 2023

Copyright©2023 ASRock Rack INC. All rights reserved.

## Copyright Notice:

No part of this documentation may be reproduced, transcribed, transmitted, or translated in any language, in any form or by any means, except duplication of documentation by the purchaser for backup purpose, without written consent of ASRock Rack Inc.

Products and corporate names appearing in this documentation may or may not be registered trademarks or copyrights of their respective companies, and are used only for identification or explanation and to the owners' benefit, without intent to infringe.

## Disclaimer:

Specifications and information contained in this documentation are furnished for informational use only and subject to change without notice, and should not be construed as a commitment by ASRock Rack. ASRock Rack assumes no responsibility for any errors or omissions that may appear in this documentation.

With respect to the contents of this documentation, ASRock Rack does not provide warranty of any kind, either expressed or implied, including but not limited to the implied warranties or conditions of merchantability or fitness for a particular purpose.

In no event shall ASRock Rack, its directors, officers, employees, or agents be liable for any indirect, special, incidental, or consequential damages (including damages for loss of profits, loss of business, loss of data, interruption of business and the like), even if ASRock Rack has been advised of the possibility of such damages arising from any defect or error in the documentation or product.



### WARNING

**THIS PRODUCT CONTAINS A BUTTOON BATTERY**

If swallowed, a button battery can cause serious injury or death.

Please keep batteries out of sight or reach of children.

## CALIFORNIA, USA ONLY

The Lithium battery adopted on this motherboard contains Perchlorate, a toxic substance controlled in Perchlorate Best Management Practices (BMP) regulations passed by the California Legislature. When you discard the Lithium battery in California, USA, please follow the related regulations in advance.

“Perchlorate Material-special handling may apply, see [www.dtsc.ca.gov/hazardouswaste/perchlorate](http://www.dtsc.ca.gov/hazardouswaste/perchlorate)”

## AUSTRALIA ONLY

Our goods come with guarantees that cannot be excluded under the Australian Consumer Law. You are entitled to a replacement or refund for a major failure and compensation for any other reasonably foreseeable loss or damage caused by our goods. You are also entitled to have the goods repaired or replaced if the goods fail to be of acceptable quality and the failure does not amount to a major failure. If you require assistance please call ASRock Rack Tel : +886-2-55599600 ext.123 (Standard International call charges apply)



This device complies with Part 15 of the FCC Rules. Operation is subject to the following two conditions:

- (1) this device may not cause harmful interference, and
- (2) this device must accept any interference received, including interference that may cause undesired operation.

This equipment has been tested and found to comply with the limits for a Class B digital device, pursuant to part 15 of the FCC Rules. These limits are designed to provide reasonable protection against harmful interference in a residential installation. This equipment generates, uses and can radiate radio frequency energy and, if not installed and used in accordance with the instructions, may cause harmful interference to radio communications. However, there is no guarantee that interference will not occur in a particular installation. If this equipment does cause harmful interference to radio or television reception, which can be determined by turning the equipment off and on, the user is encouraged to try to correct the interference by one or more of the following measures:

- Reorient or relocate the receiving antenna.
- Increase the separation between the equipment and receiver.
- Connect the equipment into an outlet on a circuit different from that to which the receiver is connected.
- Consult the dealer or an experienced radio/TV technician for help.



ASRock Rack INC. hereby declares that this device is in compliance with the essential requirements and other relevant provisions of related Directives. Full text of EU declaration of conformity is available at: <http://www.asrockrack.com>

ASRock Rack follows the green design concept to design and manufacture our products, and makes sure that each stage of the product life cycle of ASRock Rack product is in line with global environmental regulations. In addition, ASRock Rack disclose the relevant information based on regulation requirements.

Please refer to <https://www.asrockrack.com/general/about.asp?cat=Responsibility> for information disclosure based on regulation requirements ASRock Rack is complied with:



ASRock Rack INC. hereby declares that this device is in compliance with the essential requirements and other relevant provisions of related UKCA Directives. Full text of UKCA declaration of conformity is available at: <http://www.asrockrack.com>



DO NOT throw the motherboard in municipal waste. This product has been designed to enable proper reuse of parts and recycling. This symbol of the crossed out wheeled bin indicates that the product (electrical and electronic equipment) should not be placed in municipal waste. Check local regulations for disposal of electronic products.

## Contents

<b>Chapter 1 Introduction</b>	<b>1</b>
1.1 Package Contents	1
1.2 Specifications	2
1.3 Unique Features	5
1.4 Motherboard Layout	6
1.5 Onboard LED Indicators	9
1.6 I/O Panel	10
1.7 Block Diagram	12
<b>Chapter 2 Installation</b>	<b>13</b>
2.1 Screw Holes	13
2.2 Pre-installation Precautions	13
2.3 Installing the CPU	14
2.4 Installing the Memory Modules (DIMM)	19
2.5 Expansion Slots (PCI Express Slots)	21
2.6 Jumper Setup	22
2.7 Onboard Headers and Connectors	23
2.8 Dr. Debug	37
2.9 Identification purpose LED/Switch	43
2.10 Dual LAN and Teaming Operation Guide	44
2.11 M.2 SSD Module Installation Guide	45
<b>Chapter 3 UEFI Setup Utility</b>	<b>47</b>
3.1 Introduction	47
3.1.1 UEFI Menu Bar	47

3.1.2	Navigation Keys	48
3.2	Main Screen	49
3.2.1	Motherboard Information	50
3.2.2	Processor Information	50
3.2.3	Memory Information	51
3.3	Advanced Screen	52
3.3.1	CPU Configuration	53
3.3.2	Chipset Configuration	54
3.3.3	Storage Configuration	56
3.3.4	NVMe Configuration	57
3.3.5	ACPI Configuration	58
3.3.6	USB Configuration	59
3.3.7	Super IO Configuration	60
3.3.8	Serial Port Console Redirection	61
3.3.9	H/W Monitor	64
3.3.10	PCI Subsystem Settings	65
3.3.11	AMD CBS	66
3.3.12	AMD PBS	67
3.3.13	PSP Firmware Versions	69
3.3.14	Network Stack Configuration	70
3.3.15	Driver Health	72
3.3.16	Tls Auth Configuration	73
3.3.17	Instant Flash	74
3.4	Security	75

3.4.1	Key Management	76
3.5	Server Mgmt	79
3.5.1	BMC Network Configuration	81
3.5.2	System Event Log	83
3.5.3	BMC Tools	84
3.6	Event Logs	85
3.7	Boot Screen	87
3.8	Exit Screen	89
<b>Chapter 4 Software Support</b>		<b>90</b>
4.1	Download and Install Operating System	90
4.2	Download and Install Software Drivers	90
4.3	Contact Information	90
<b>Chapter 5 Troubleshooting</b>		<b>91</b>
5.1	Troubleshooting Procedures	91
5.2	Technical Support Procedures	93
5.3	Returning Merchandise for Service	93

# Chapter 1 Introduction

Thank you for purchasing ASRock Rack **GENOAD12M3-2Q** motherboard, a reliable motherboard produced under ASRock Rack's consistently stringent quality control. It delivers excellent performance with robust design conforming to ASRock Rack's commitment to quality and endurance.

In this manual, chapter 1 and 2 contains introduction of the motherboard and step-by-step guide to the hardware installation. Chapter 3 and 4 contains the configuration guide to BIOS setup and information of the Software Support.



*Because the motherboard specifications and the BIOS software might be updated, the content of this manual will be subject to change without notice. In case any modifications of this manual occur, the updated version will be available on ASRock Rack website without further notice. Find the latest memory and CPU support lists on ASRock Rack website as well. ASRock Rack's Website: [www.ASRockRack.com](http://www.ASRockRack.com)*

*For the technical support related to this motherboard, please visit the website about specific information.  
<http://www.asrockrack.com/support/>*

## 1.1 Package Contents

- ASRock Rack GENOAD12M3-2Q Motherboard  
(9.6in x 13.4in, 24.38cm x 34.04cm)
- Quick Installation Guide
- 1 x I/O Shield
- 1 x MCIO X8 to 8 SATA +8P Cable (63cm)
- 2 x Screws for M.2 Sockets



*If any items are missing or appear damaged, contact the authorized dealer.*

## 1.2 Specifications

<b>GENOAD12M3-2Q</b>	
<b>MB Physical Status</b>	
Dimension	9.6" x 13.4" (24.38cm x 34.04cm)
<b>Processor System</b>	
CPU	AMD EPYC 9004 series processors
Socket	Single Socket SP5 (SM-LGA-6096)
Thermal Design Power	400W
Chipset	System on Chip
<b>System Memory</b>	
Capacity	12 DIMM slots (1DPC)
Type	DDR5 288-pin RDIMM, RDIMM-3DS
Max. Capacity per DIMM	RDIMM: 64GB (2R) RDIMM-3DS: 512GB (258Rx4)
Max. DIMM Frequency	4800MHz
Voltage	1.1V
<i>Note: Memory capacity, frequency, and voltage support is to be validated</i>	
<b>Expansion Slot (Slot7 close to CPU)</b>	
SLOT7	PCIe5.0 / CXL1.1 x16
SLOT6	PCIe5.0 / CXL1.1 x16
<b>Other PCIe Expansion Connectors</b>	
M.2	2 M-key (PCIe5.0 / CXL1.1 x4 or 4 SATA 6Gb/s), supports 2260/2280/22110 form factor
MCIO	6 MCIO (PCIe5.0 x8) 2 MCIO (PCIe5.0 x8 or 8 SATA 6Gb/s)
<b>Storage</b>	
CPU Built-in Storage	AMD EPYC 9004 (Up to 24 SATA 6Gb/s): 2 MCIO, 8 SATA via optional M2U2_HD_G4 M.2 device
<b>Ethernet</b>	
Additional Ethernet Controller	Broadcom BCM57414: 2 SFP28 (25GbE) Intel® i210: 2 RJ45 (1GbE)
OCP	1 OCP NIC 3.0 (PCIe5.0 / CLX1.1 x16)
<b>Graphics</b>	
Controller	ASPEED AST2600: 1 (15-pin) header
<b>Security</b>	
TPM	1 (13-pin, SPI)
<b>Rear Panel I/O</b>	
UID Button/LED	1 UID button
USB	2 Type A (USB3.2 Gen1)
RJ45	2 SFP28 (25GbE), 1 dedicated IPMI



Internal Connectors/Headers	
PSU Connector	1 (24-pin, ATX main power), 3 (8-pin, ATX 12V)
Auxiliary Panel Header	1 (18-pin): chassis intrusion, system fault LED, LAN1/LAN2 activity LED, locate, SMBus
System Panel Header	1 (9-pin): power switch, reset switch, system power LED, HDD activity LED
NMI Button	1
COM Header	1 (9-pin)
VGA Header	1
Speaker Header	1 (4-pin)
Fan Header	8 (6-pin)
Thermal Sensor Header	1
TPM header	1 (13-pin, SPI)
SGPIO Header	4
HSBP	1
SMBus Header	1
PMBus Header	1
IPMB Header	1
Buzzer	1
Clear CMOS	1 (contact pads)
Others	1 ME manufacture mode header
LED Indicators	
Standby Power LED	1 (5VSB)
80 Debug Port LED	1
Fan Fail LED	8
BMC Heartbeat LED	1
System BIOS	
Type	AMI UEFI BIOS; 256 Mb (32MB) SPI Flash ROM
Features	ASRock Rack Instant Flash, ACPI 6.4 and above compliance wake up events, SMBIOS 3.5.0 and above, Plug and Play(PnP)
Hardware Monitor	
Temperature	CPU, MB, TR1 Temperature sensing
Fan	CPU/Rear/Front Fan Tachometer CPU Quiet Fan (Allow Chassis Fan Speed Auto-Adjust by CPU Temperature) CPU/Rear/Front Fan Multi-Speed Control
Voltage	VOLT_3VSB, VOLT_5VSB, VOLT_VCORE0, VOLT_VCORE1, VOLT_P0_VSOC, VOLT_VDD_11, VOLT_VDDIO, VOLT_VDD_33, VOLT_VDD_18, VOLT_BAT, VOLT_3V, VOLT_5V, VOLT_12V
Server Management	
BMC Controller	ASPEED AST2600: IPMI2.0 with iKVM and vMedia support

IPMI Dedicated GLAN	1 RJ45 Dedicated IPMI LAN port by Realtek RTL8211F
<b>Support OS</b>	
OS	<p>Microsoft® Windows®:</p> <ul style="list-style-type: none"> <li>- Server 2019 (64bit)</li> <li>- Server 2022 (64bit)</li> </ul> <p>Linux®:</p> <ul style="list-style-type: none"> <li>- RedHat Enterprise Linux Server 8.6 (64bit)/9.0 (64bit)</li> <li>- SUSE SLES 15.4 (64bit)</li> <li>- UBuntu 20.04.5 (64bit)/22.04 (64bit)</li> </ul> <p>Hypervisor:</p> <ul style="list-style-type: none"> <li>- VMWare® ESXi/7.0 U3i/8.0</li> <li>- CITRIX Hypervisor 8.2.1</li> </ul> <p><i>*Please refer to our website for the latest OS support list.</i></p>
<b>Environment</b>	
Operating temperature	10 - 35°C (50 - 95 degF)
Non-operating temperature	-40 - 70°C (-40 - 158degF)

NOTE: Please refer to our website for the latest specifications.



This motherboard supports Wake from on Board LAN. To use this function, please make sure that the "Wake on Magic Packet from power off state" is enabled in Device Manager > Intel® Ethernet Connection > Power Management. And the "PCI Devices Power On" is enabled in UEFI SETUP UTILITY > Advanced > ACPI Configuration. After that, onboard LAN1&2 can wake up S5 under OS.



Install Intel® LAN utility or Marvell SATA utility, this motherboard may fail Windows® Hardware Quality Lab (WHQL) certification tests. If installing the drivers only, it will pass the WHQL tests.

## 1.3 Unique Features

ASRock Rack Instant Flash is a BIOS flash utility embedded in Flash ROM. This convenient BIOS update tool allows user to update system BIOS without entering operating systems first like MS-DOS or Windows. With this utility, pressing the <F6> key during the POST or the <F2> key to enter into the BIOS setup menu to access ASRock Rack Instant Flash. Just launch this tool and save the new BIOS file to the USB flash drive, floppy disk or hard drive, then update the BIOS only in a few clicks without preparing an additional floppy diskette or other complicated flash utility. Please be noted that the USB flash drive or hard drive must use FAT32/16/12 file system.

# 1.4 Motherboard Layout

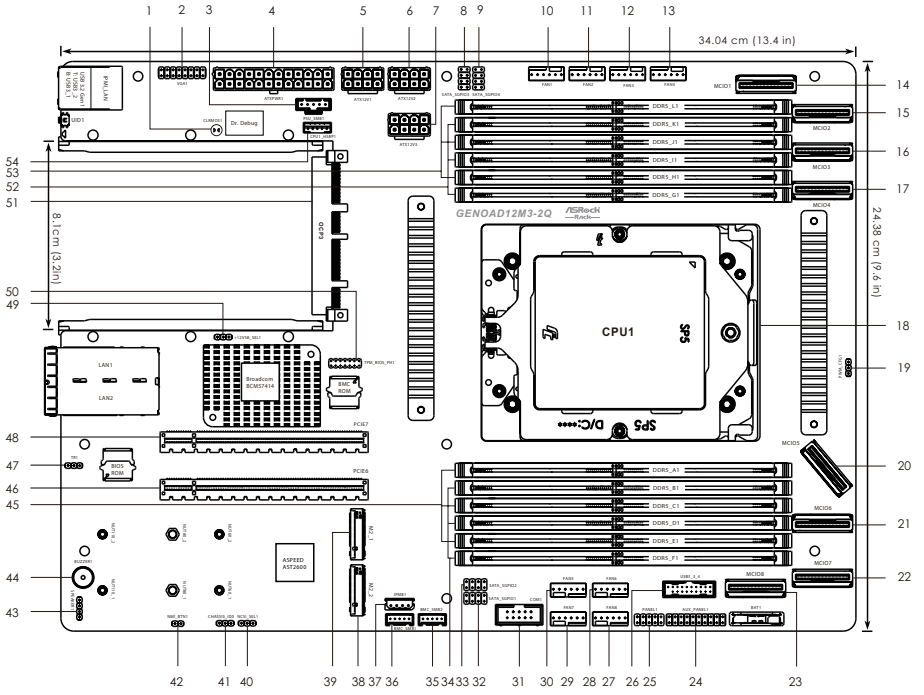

No.	Description
1	Clear CMOS Pad (CLRMOS1)
2	Front VGA Header (VGA1)
3	PSU SMBus Header (PSU_SMB1)
4	ATX Power Connector (ATXPWR1)
5	ATX 12V Power Connector (ATX12V1)
6	ATX 12V Power Connector (ATX12V2)
7	ATX 12V Power Connector (ATX12V3)
8	SATA SGPIO Connector (SATA_SGPIO3)
9	SATA SGPIO Connector (SATA_SGPIO4)
10	System Fan Connector (FAN1)
11	System Fan Connector (FAN2)
12	System Fan Connector (FAN3)
13	System Fan Connector (FAN4)
14	Mini Cool Edge IO Connector (MCIO1)
15	Mini Cool Edge IO Connector (MCIO2)
16	Mini Cool Edge IO Connector (MCIO3)
17	Mini Cool Edge IO Connector (MCIO4)
18	AMD Socket SP5 (SM-LGA-6096) (CPU1)
19	PWM Configuration Header (PWM_CFG1)
20	Mini Cool Edge IO Connector (MCIO5)
21	Mini Cool Edge IO Connector (MCIO6)
22	Mini Cool Edge IO Connector (MCIO7)
23	Mini Cool Edge IO Connector (MCIO8)
24	Auxiliary Panel Header (AUX_PANEL1)
25	System Panel Header (PANEL1)
26	USB 3.2 Gen1 Header (USB3_3_4)
27	System Fan Connector (FAN8)
28	System Fan Connector (FAN6)
29	System Fan Connector (FAN7)
30	System Fan Connector (FAN5)
31	COM Port Header (COM1)
32	SATA SGPIO Connector (SATA_SGPIO1)
33	SATA SGPIO Connector (SATA_SGPIO2)

No.	Description
34	3 x 288-pin DDR5 DIMM Slots (DDR5_B1, DDR5_D1, DDR5_F1)*
35	MC SMBus Header (BMC_SMB2)
36	MC SMBus Header (BMC_SMB1)
37	Intelligent Platform Management Bus Header (IPMB1)
38	M.2 Socket (M2_2) (Type 2260/2280/22110)
39	M.2 Socket (M2_1) (Type 2260/2280/22110)
40	NCSI Mode Jumper (NCSI_SEL1)
41	Chassis ID Jumper (CHASSIS_ID0)
42	Non Maskable Interrupt Button (NMI_BTN1)
43	Speaker Header (SPEAKER1)
44	Buzzer (BUZZER1)
45	3 x 288-pin DDR5 DIMM Slots (DDR5_A1, DDR5_C1, DDR5_E1)*
46	PCI Express 5.0 x16 Slot (PCIE6)
47	Thermal Sensor Header (TR1)
48	PCI Express 5.0 x16 Slot (PCIE7)
49	OCP3 +12VSB Power Jumper (+12VSB_SEL1)
50	SPI TPM Header (TPM_BIOS_PH1)
51	OCP NIC 3.0 Slot (PCIe5.0 x16) (OCP3)
52	3 x 288-pin DDR5 DIMM Slots (DDR5_G1, DDR5_I1, DDR5_K1)*
53	3 x 288-pin DDR5 DIMM Slots (DDR5_H1, DDR5_J1, DDR5_L1)*
54	Backplane PCI Express Hot-Plug Connector (CPU1_HSBP1)

\* For DIMM installation and configuration instructions, please see p.19 (Installation of Memory Modules (DIMM)) for more details.

## 1.5 Onboard LED Indicators

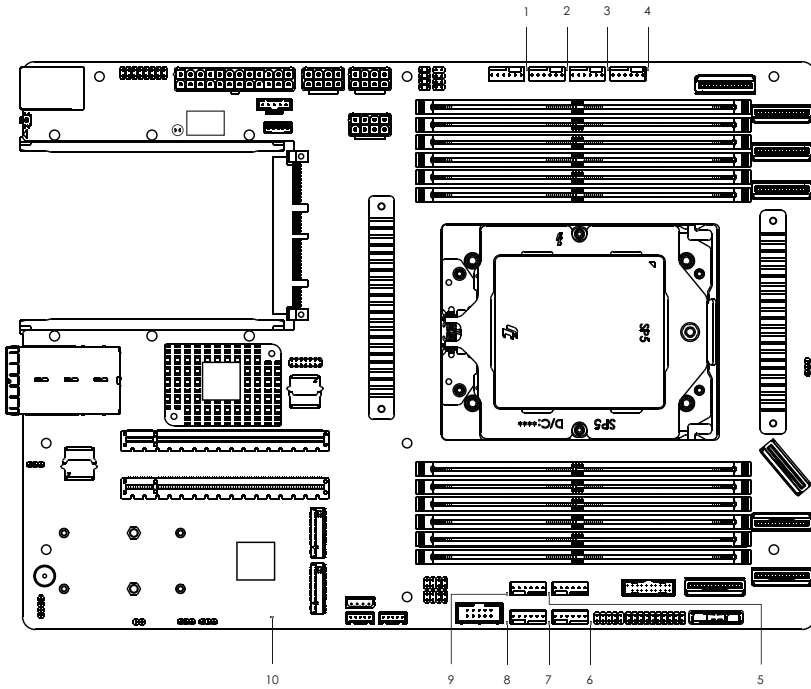

No.	Item	Status	Description
1	LED_FAN1	Red	FAN1 failed
2	LED_FAN2	Red	FAN2 failed
3	LED_FAN3	Red	FAN3 failed
4	LED_FAN4	Red	FAN4 failed
5	LED_FAN6	Red	FAN6 failed
6	SB_PWR1	Green	STB PWR ready
7	LED_FAN8	Red	FAN8 failed
8	LED_FAN7	Red	FAN7 failed
9	LED_FAN5	Red	FAN5 failed
10	BMC_LED1	Green	BMC heartbeat LED

## 1.6 I/O Panel

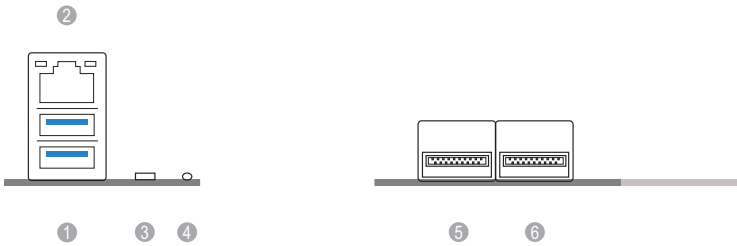

No.	Description	No.	Description
1	USB 3.2 Gen1 Ports (USB3_1_2)	4	UID LED (UID_LED1)
2	IPMI LAN Header (IPMI_LAN)*	5	25G SFP28 (Fiber) (LAN1)**
3	UID Switch (UID1)	6	25G SFP28 (Fiber) (LAN2)**

### LAN Port LED Indications

\*There is an LED on each side of IPMI LAN port. Please refer to the table below for the LAN port LED indications.

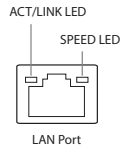

### IPMI LAN Port LED Indications

Activity / Link LED		Speed LED	
Status	Description	Status	Description
Off	No Link	Off	10Mbps connection or no link
Blinking Yellow	Data Activity	Orange	100Mbps connection
On	Link	Green	1Gbps connection



\*\*There is an LED on each side of SFP LAN port. Please refer to the table below for the LAN port LED indications.

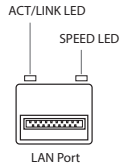

#### SFP LAN Port (LAN1, LAN2) LED Indications

Activity / Link LED		Speed LED	
Status	Description	Status	Description
Off	No Link	Off	1G/100Mbps connection or no connection
Blinking Yellow	Data Activity	Orange	10Gbps connection
On	Link	Green	25Gbps connection

# 1.7 Block Diagram

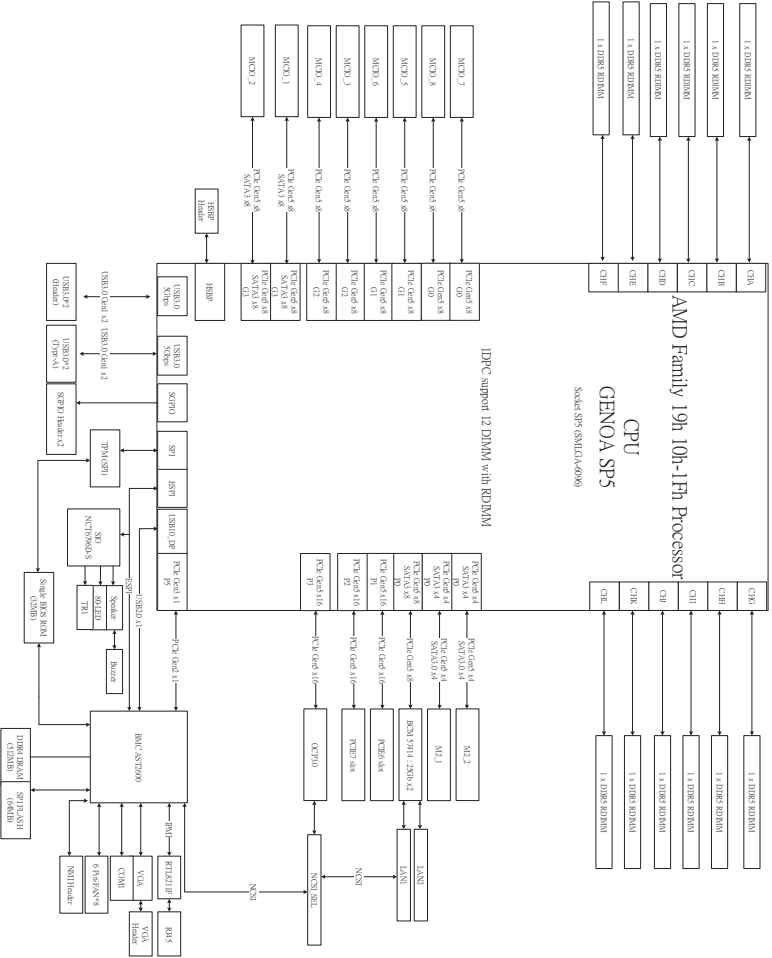

## Chapter 2 Installation

This is a 9.6" x 13.4" (24.38cm x 34.04cm) motherboard. Before installing the motherboard, study the configuration of the chassis to ensure that the motherboard fits into it.



*Make sure to unplug the power cord before installing or removing the motherboard. Failure to do so may cause physical injuries and damages to the motherboard components.*

### 2.1 Screw Holes

Place screws into the holes indicated by circles to secure the motherboard to the chassis.



*Do not over-tighten the screws! Doing so may damage the motherboard.*

### 2.2 Pre-installation Precautions

Take note of the following precautions before installing motherboard components or change any motherboard settings.

1. Unplug the power cord from the wall socket before touching any components.
2. To avoid damaging the motherboard's components due to static electricity, NEVER place the motherboard directly on the carpet or the like. Also remember to use a grounded wrist strap or touch a safety grounded object before handling the components.
3. Hold components by the edges and do not touch the ICs.
4. Whenever uninstall any component, place it on a grounded anti-static pad or in the bag that comes with the component.
5. When placing screws into the screw holes to secure the motherboard to the chassis, please do not over-tighten the screws! Doing so may damage the motherboard.



*Before installing or remove any component, ensure that the power is switched off or the power cord is detached from the power supply. Failure to do so may cause severe damage to the motherboard, peripherals, and/or components.*

## 2.3 Installing the CPU



1. Before inserting the CPU into the socket, please check if the PnP cap is on the socket, if the CPU surface is unclean, or if there are any bent pins in the socket. Do not force to insert the CPU into the socket if above situation is found. Otherwise, the CPU will be seriously damaged.
2. Unplug all power cables before installing the CPU.

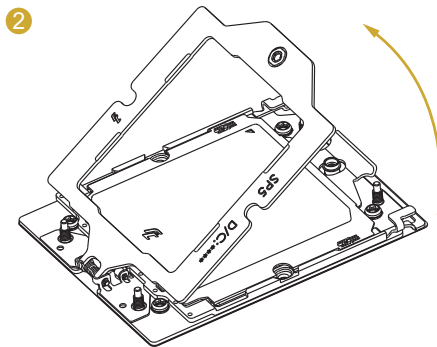
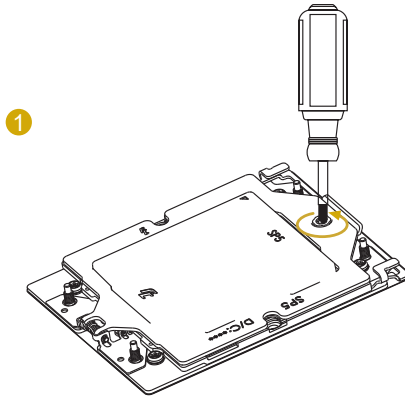

3

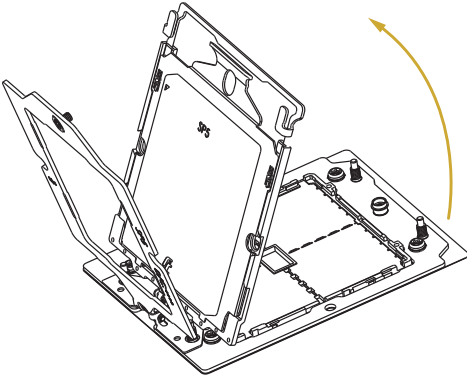

4

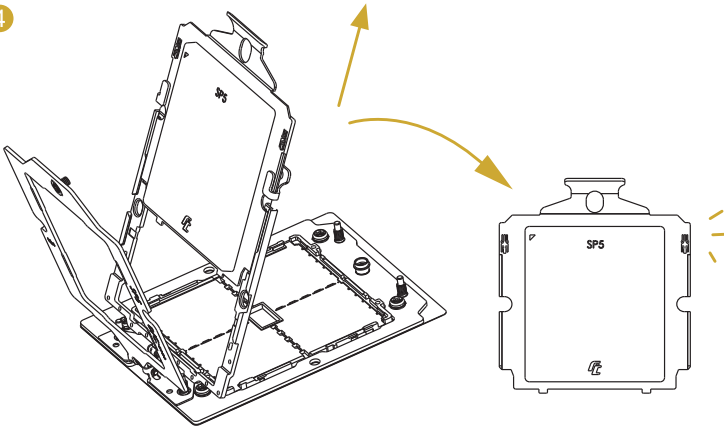

5

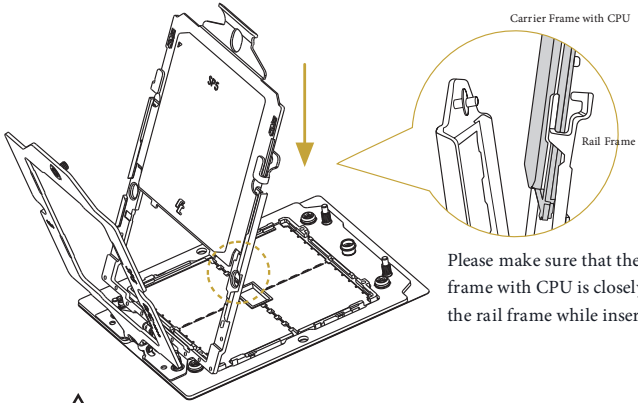

Install the carrier frame with CPU. Don't separate them.

6

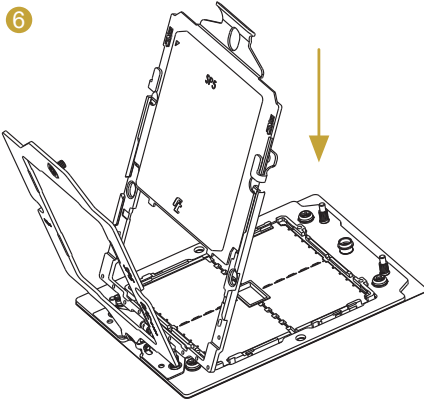

7

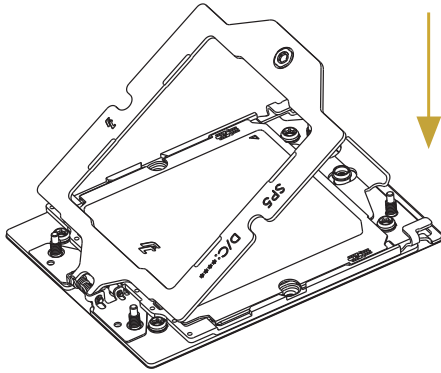

8

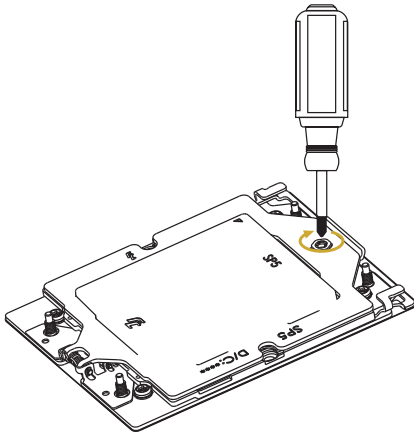

9

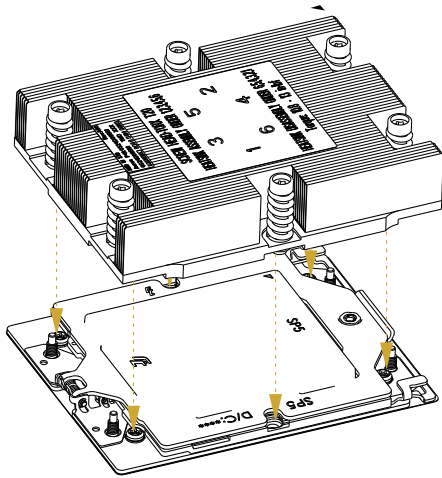

10

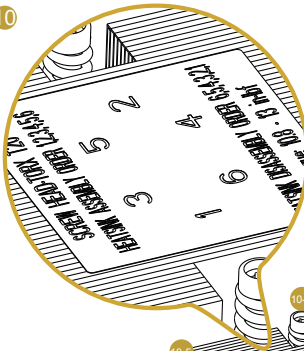

Set your torque wrench to 1.54 in-lb.  
One fourth a turn each time.

Tighten the screws in a sequential order  
1 > 2 > 3 > 4 > 5 > 6.

Loosen the screws in a reverse order.

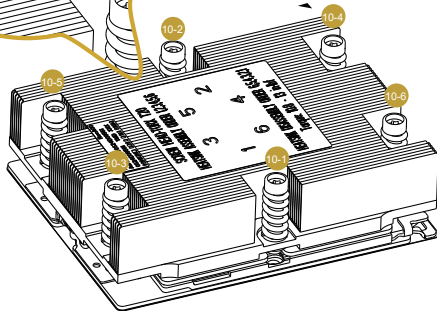



## 2.4 Installing the Memory Modules (DIMM)

This motherboard provides twelve 288-pin DDR5 (Double Data Rate 5) DIMM slots in two groups, and supports Twelve Channel Memory Technology.



1. installing a memory module, make sure to turn off the computer and unplug the power-cord from the power outlet to prevent damage to the memory module.
2. It is not allowed to install a DDR, DDR2, DDR3 or DDR4 memory module into a DDR5 slot; otherwise, this motherboard and DIMM may be damaged.
3. For Twelve channel configuration, it always needs to install identical (the same brand, speed, size and chip-type) DDR5 DIMMs.

### Recommended Memory Configurations

	CPU1					
	1 DIMM	2 DIMMS	4 DIMMS	8 DIMMS	10 DIMMS	12 DIMMS
A1	V	V	V	V	V	V
B1				V	V	V
C1			V	V	V	V
D1					V	V
E1				V	V	V
F1						V
G1		V	V	V	V	V
H1				V	V	V
I1			V	V	V	V
J1					V	V
K1				V	V	V
L1						V

The symbol V indicates the slot is populated.

1

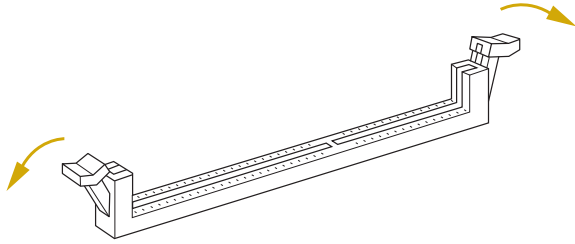

2

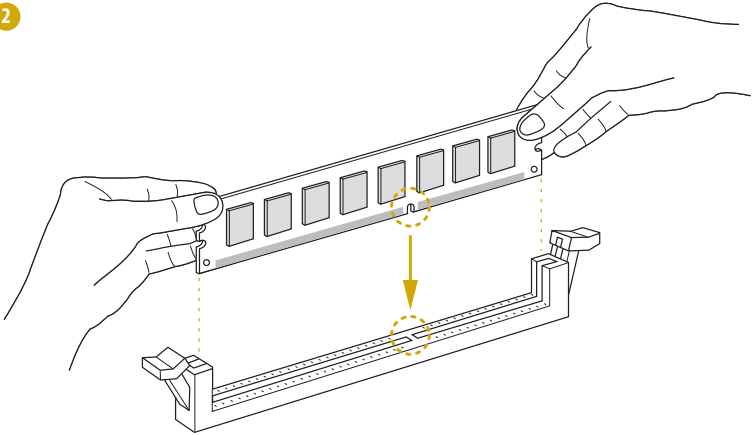

3

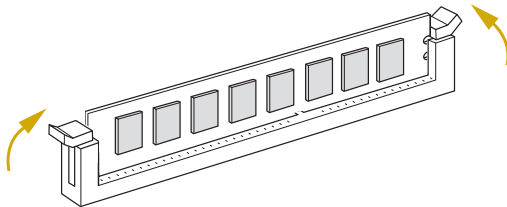

## 2.5 Expansion Slots (PCI Express Slots)

There are two PCI Express slots on this motherboard.

### PCIe slots:

PCIe6 (PCIe 5.0 x16 slot, from CPU1) is used for PCI Express x16 lane width cards.

PCIe7 (PCIe 5.0 x16 slot, from CPU1) is used for PCI Express x16 lane width cards.

Slot	Generation	Mechanical	Electrical	Source
PCIe6	5.0	x16	x16	CPU1
PCIe7	5.0	x16	x16	CPU1

### Installing an expansion card

- Step 1. Before installing an expansion card, please make sure that the power supply is switched off or the power cord is unplugged. Please read the documentation of the expansion card and make necessary hardware settings for the card before starting the installation.
- Step 2. Remove the system unit cover (if the motherboard is already installed in a chassis).
- Step 3. Remove the bracket facing the slot that intending to use. Keep the screws for later use.
- Step 4. Align the card connector with the slot and press firmly until the card is completely seated on the slot.
- Step 5. Fasten the card to the chassis with screws.
- Step 6. Replace the system cover.

## 2.6 Jumper Setup

The illustration shows how jumpers are setup. When the jumper cap is placed on the pins, the jumper is “Short”. If no jumper cap is placed on the pins, the jumper is “Open”. The illustration shows a 3-pin jumper whose pin1 and pin2 are “Short” when a jumper cap is placed on these 2 pins.

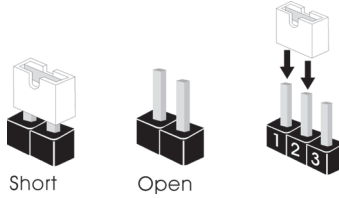

NCSI Mode Jumper  
(3-pin NCSI\_SEL1)  
(see p.6, No. 41)



NCSI for BCM7414  
(Default)



NCSI for OCP NIC

Chassis ID Jumper  
(3-pin CHASSIS\_ID0)  
(see p.6, No. 42)



Pull-up, for BMC further  
use (Default)



Pull-down, for BMC further  
use

OCP3 +12VSB Power Jumper  
(3-pin +12VSB\_SEL1)  
(see p.6, No. 49  
)



Enable +12VSB for OCP3  
PWR (Default)



Disable +12VSB for OCP3  
PWR

## 2.7 Onboard Headers and Connectors



Onboard headers and connectors are NOT jumpers. Do NOT place jumper caps over these headers and connectors. Placing jumper caps over the headers and connectors will cause permanent damage to the motherboard.

System Panel Header  
(9-pin PANEL1)  
(see p.6, No. 26)

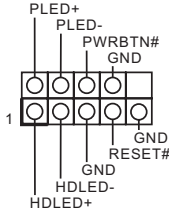

Connect the power switch, reset switch and system status indicator on the chassis to this header according to the pin assignments. Particularly note the positive and negative pins before connecting the cables.



**PWRBTN (Power Switch):**

Connect to the power switch on the chassis front panel. Configure the way to turn off the system using the power switch.

**RESET (Reset Switch):**

Connect to the reset switch on the chassis front panel. Press the reset switch to restart the computer if the computer freezes and fails to perform a normal restart.

**PLED (System Power LED):**

Connect to the power status indicator on the chassis front panel. The LED is on when the system is operating. The LED is off when the system is in S4 sleep state or powered off (S5).

**HDLED (Hard Drive Activity LED):**

Connect to the hard drive activity LED on the chassis front panel. The LED is on when the hard drive is reading or writing data.

The front panel design may differ by chassis. A front panel module mainly consists of power switch, reset switch, power LED, hard drive activity LED, speaker and etc. When connecting the chassis front panel module to this header, make sure the wire assignments and the pin assignments are matched correctly.

**Auxiliary Panel Header**  
(18-pin AUX\_PANEL1)  
(see p.6, No. 25)

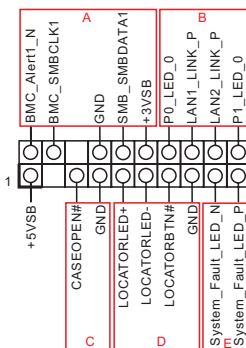

This header supports multiple functions on the front panel, including front panel SMB, internet status indicator.



**A. Front panel SMBus connecting pin (6-1 pin FPSMB)**

This header allows user to connect SMBus (System Management Bus) equipment. It can be used for communication between peripheral equipment in the system, which has slower transmission rates, and power management equipment.

**B. Internet status indicator (2-pin LAN1\_LED, LAN2\_LED)**

These two 2-pin headers allow user to use the Gigabit internet indicator cable to connect to the LAN status indicator. When this indicator flickers, it means that the internet is properly connected.

**C. Chassis intrusion pin (2-pin CHASSIS)**

This header is provided for host computer chassis with chassis intrusion detection designs. In addition, it must also work with external detection equipment, such as a chassis intrusion detection sensor or a microswitch. When this function is activated, if any chassis component movement occurs, the sensor will immediately detect it and send a signal to this header, and the system will then record this chassis intrusion event. The default setting is set to the CASEOPEN and GND pin; this function is off.

**D. Locator LED (4-pin LOCATOR)**

This header is for the locator switch and LED on the front panel.

**E. System Fault LED (2-pin LOCATOR)**

This header is for the Fault LED on the system.

**Front VGA Header**  
(15-pin VGA1)  
(see p.6, No. 2)

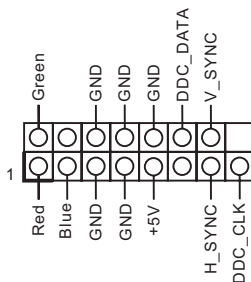

Please connect either end of VGA\_2X8 cable to VGA header.

USB 3.2 Gen1 Header  
(19-pin USB3\_3\_4)  
(see p.6, No. 27)

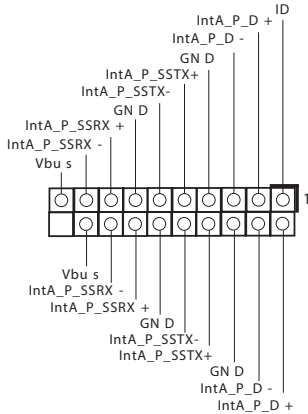

Besides two default USB 3.2 Gen1 ports on the I/O panel, there is one USB 3.2 Gen1 header on this motherboard. This USB 3.2 Gen1 header can support two USB 3.2 Gen1 ports.

PSU SMBus Header  
(PSU\_SMB1)  
(see p.6, No. 27)

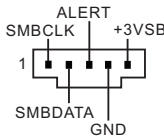

PSU SMBus monitors the status of the power supply, fan and system temperature.

Non Maskable Interrupt Button Header  
(2-pin NMI\_BTN1)  
(see p.6, No. 43)



Please connect a NMI device to this header.

BMC SMB Header  
(5-pin BMC\_SMB1)  
(see p.6, No. 37)  
(5-pin BMC\_SMB2)  
(see p.6, No. 36)

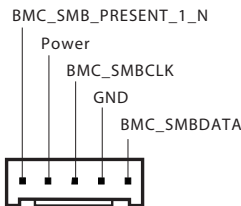

The header is used for the SMBUS devices.

Backplane PCI Express Hot-Plug Connector  
(5-pin CPU1\_HSBP1)  
(see p.6, No. 54)

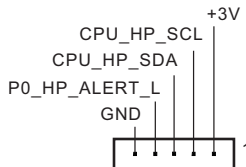

The header is used for the hot plug feature of HDDs on the backplane.

### System Fan Connectors

- (6-pin FAN1)  
(see p.6, No. 10)
- (6-pin FAN2)  
(see p.6, No. 11)
- (6-pin FAN3)  
(see p.6, No. 12)
- (6-pin FAN4)  
(see p.6, No. 13)

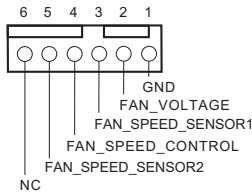

Please connect fan cables to the fan connectors and match the black wire to the ground pin. All fans support Fan Control.

- (6-pin FAN5)  
(see p.6, No. 30)
- (6-pin FAN6)  
(see p.6, No. 28)
- (6-pin FAN7)  
(see p.6, No. 29)
- (6-pin FAN8)  
(see p.6, No. 27)

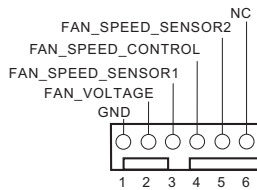

### SPI TPM Header

- (13-pin TPM\_BIOS\_PH1)  
(see p.6, No. 50)

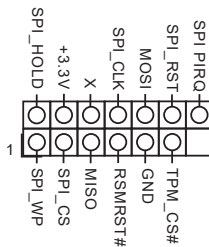

This connector supports SPI Trusted Platform Module (TPM) system, which can securely store keys, digital certificates, passwords, and data. A TPM system also helps enhance network security, protects digital identities, and ensures platform integrity.

### Serial Port Header

- (9-pin COM1)  
(see p.6, No. 32)

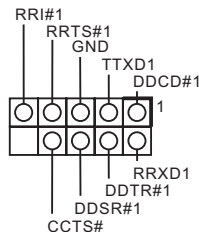

This COM header supports a serial port module.



ATX Power Connector  
(24-pin ATXPWR1)  
(see p.6, No. 4)

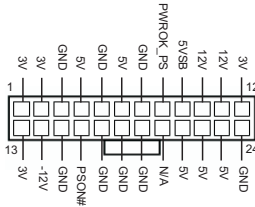

This motherboard provides a 24-pin ATX power connector. To use a 20-pin ATX power supply, please plug it along Pin 1 and Pin 13.

ATX Power Connectors  
(8-pin ATX12V1)  
(see p.6, No. 6)  
(8-pin ATX12V2)  
(see p.6, No. 7)  
(8-pin ATX12V3)  
(see p.6, No. 8)

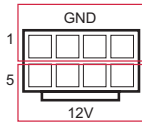

This motherboard provides three ATX power connectors.

Intelligent Platform  
Management Bus Header  
(4-pin IPMB1)  
(see p.6, No. 38)

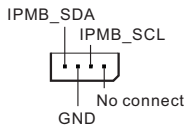

This 4-pin connector is used to provide a cabled baseboard or front panel connection for value added features and 3rd-party add-in cards, such as Emergency Management cards, that provide management features using the IPMB.

Serial General Purpose  
Input/Output Headers  
(7-pin SATA\_SGPIO1)  
(see p.6, No. 33)  
(7-pin SATA\_SGPIO2)  
(see p.6, No. 34)

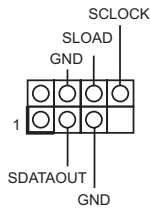

These headers support Serial Link interface for onboard SATA connections.

(7-pin SATA\_SGPIO3)  
(see p.6, No. 9)  
(7-pin SATA\_SGPIO4)  
(see p.6, No. 10)

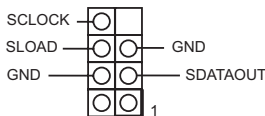

---

Thermal Sensor Header  
(3-pin TR1)  
(see p.6, No. 47)



Please connect the thermal sensor cable to either pin 1-2 or pin 2-3 and the other end to the device that wants to monitor the temperature.

---

PWM Configuration Header  
(3-pin PWM\_CFG1)  
(see p.6, No. 20)

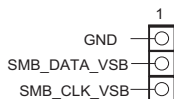

This header is used for PWM configurations.

---

Speaker Header  
(4-pin SPEAKER1)  
(see p.6, No. 45)

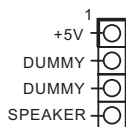

Please connect the chassis speaker to this header.

---

Clear CMOS Pad  
(CLRCMOS1)  
(see p.6, No. 1)



This allows user to clear the data in CMOS. To clear CMOS, take out the CMOS battery and short the Clear CMOS Pad.

---

MCIO Connectors  
(MCIO1)  
(see p.6, No. 15)  
(MCIO2)  
(see p.6, No. 16)  
(MCIO3)  
(see p.6, No. 17)  
(MCIO4)  
(see p.6, No. 18)  
(MCIO5)  
(see p.6, No. 21)  
(MCIO6)  
(see p.6, No. 22)  
(MCIO7)  
(see p.6, No. 23)  
(MCIO8)  
(see p.6, No. 24)

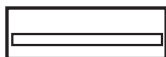

These connectors are used for the PCIE devices.

## MCIO1 Pin Definition

Pin	Definition	Pin	Definition
A1	GND	B1	GND
A2	G3_RXP0	B2	G3_TXP0
A3	G3_RXN0	B3	G3_TXN0
A4	GND	B4	GND
A5	G3_RXP1	B5	G3_TXP1
A6	G3_RXN1	B6	G3_TXN1
A7	GND	B7	GND
A8	BP_TYPE	B8	SCL
A9	PCIE_WAKE#	B9	SDA
A10	GND	B10	GND
A11	DP	B11	BUF_RST0_L
A12	DN	B12	R_PRSNT_N
A13	GND	B13	GND
A14	G3_RXP2	B14	G3_TXP2
A15	G3_RXN2	B15	G3_TXN2
A16	GND	B16	GND
A17	G3_RXP3	B17	G3_TXP3
A18	G3_RXN3	B18	G3_TXN3
A19	GND	B19	GND
A20	G3_RXP4	B20	G3_TXP4
A21	G3_RXN4	B21	G3_TXN4
A22	GND	B22	GND
A23	G3_RXP5	B23	G3_TXP5
A24	G3_RXN5	B24	G3_TXN5
A25	GND	B25	GND
A26	BP_TYPE	B26	SCL
A27	PCIE_WAKE#	B27	SDA
A28	GND	B28	GND
A29	DP	B29	BUF_RST0_L
A30	DN	B30	R_PRSNT_N
A31	GND	B31	GND
A32	G3_RXP6	B32	G3_TXP6
A33	G3_RXN6	B33	G3_TXN6
A34	GND	B34	GND
A35	G3_RXP7	B35	G3_TXP7
A36	G3_RXN7	B36	G3_TXN7
A37	GND	B37	GND
75	NP_NC_1	76	NP_NC_2
77	PGND_1	78	PGND_3
79	PGND_2	80	PGND_4

## MCIO2 Pin Definition

Pin	Definition	Pin	Definition
A1	GND	B1	GND
A2	G3_RXP15	B2	G3_TXP15
A3	G3_RXN15	B3	G3_TXN15
A4	GND	B4	GND
A5	G3_RXP14	B5	G3_TXP14
A6	G3_RXN14	B6	G3_TXN14
A7	GND	B7	GND
A8	BP_TYPE	B8	SCL
A9	PCIE_WAKE#	B9	SDA
A10	GND	B10	GND
A11	DP	B11	BUF_RST0_L
A12	DN	B12	R_PRSNT_N
A13	GND	B13	GND
A14	G3_RXP13	B14	G3_TXP13
A15	G3_RXN13	B15	G3_TXN13
A16	GND	B16	GND
A17	G3_RXP12	B17	G3_TXP12
A18	G3_RXN12	B18	G3_TXN12
A19	GND	B19	GND
A20	G3_RXP11	B20	G3_TXP11
A21	G3_RXN11	B21	G3_TXN11
A22	GND	B22	GND
A23	G3_RXP10	B23	G3_TXP10
A24	G3_RXN10	B24	G3_TXN10
A25	GND	B25	GND
A26	BP_TYPE	B26	SCL
A27	PCIE_WAKE#	B27	SDA
A28	GND	B28	GND
A29	DP	B29	BUF_RST0_L
A30	DN	B30	R_PRSNT_N_SCLK3
A31	GND	B31	GND
A32	G3_RXP9	B32	G3_TXP9
A33	G3_RXN9	B33	G3_TXN9
A34	GND	B34	GND
A35	G3_RXP8	B35	G3_TXP8
A36	G3_RXN8	B36	G3_TXN8
A37	GND	B37	GND
75	NP_NC_1	76	NP_NC_2
77	PGND_1	78	PGND_3
79	PGND_2	80	PGND_4

## MCIO3 Pin Definition

Pin	Definition	Pin	Definition
A1	GND	B1	GND
A2	G2_RXP7	B2	G2_TXP7
A3	G2_RXN7	B3	G2_TXN7
A4	GND	B4	GND
A5	G2_RXP6	B5	G2_TXP6
A6	G2_RXN6	B6	G2_TXN6
A7	GND	B7	GND
A8	BP_TYPE	B8	SCL
A9	PCIE_WAKE#	B9	SDA
A10	GND	B10	GND
A11	DP	B11	BUF_RST0_L
A12	DN	B12	R_PRSNT_N
A13	GND	B13	GND
A14	G2_RXP5	B14	G2_TXP5
A15	G2_RXN5	B15	G2_TXN5
A16	GND	B16	GND
A17	G2_RXP4	B17	G2_TXP4
A18	G2_RXN4	B18	G2_TXN4
A19	GND	B19	GND
A20	G2_RXP3	B20	G2_TXP3
A21	G2_RXN3	B21	G2_TXN3
A22	GND	B22	GND
A23	G2_RXP2	B23	G2_TXP2
A24	G2_RXN2	B24	G2_TXN2
A25	GND	B25	GND
A26	BP_TYPE	B26	SCL
A27	PCIE_WAKE#	B27	SDA
A28	GND	B28	GND
A29	DP	B29	BUF_RST0_L
A30	DN	B30	R_PRSNT_N
A31	GND	B31	GND
A32	G2_RXP1	B32	G2_TXP1
A33	G2_RXN1	B33	G2_TXN1
A34	GND	B34	GND
A35	G2_RXP0	B35	G2_TXP0
A36	G2_RXN0	B36	G2_TXN0
A37	GND	B37	GND
75	NP_NC_1	76	NP_NC_2
77	PGND_1	78	PGND_3
79	PGND_2	80	PGND_4

## MCIO4 Pin Definition

Pin	Definition	Pin	Definition
A1	GND	B1	GND
A2	G2_RXP15	B2	G2_TXP15
A3	G2_RXN15	B3	G2_TXN15
A4	GND	B4	GND
A5	G2_RXP14	B5	G2_TXP14
A6	G2_RXN14	B6	G2_TXN14
A7	GND	B7	GND
A8	BP_TYPE	B8	SCL
A9	PCIE_WAKE#	B9	SDA
A10	GND	B10	GND
A11	DP	B11	BUF_RST0_L
A12	DN	B12	R_PRSNT_N
A13	GND	B13	GND
A14	G2_RXP13	B14	G2_TXP13
A15	G2_RXN13	B15	G2_TXN13
A16	GND	B16	GND
A17	G2_RXP12	B17	G2_TXP12
A18	G2_RXN12	B18	G2_TXN12
A19	GND	B19	GND
A20	G2_RXP11	B20	G2_TXP11
A21	G2_RXN11	B21	G2_TXN11
A22	GND	B22	GND
A23	G2_RXP10	B23	G2_TXP10
A24	G2_RXN10	B24	G2_TXN10
A25	GND	B25	GND
A26	BP_TYPE	B26	SCL
A27	PCIE_WAKE#	B27	SDA
A28	GND	B28	GND
A29	DP	B29	BUF_RST0_L
A30	DN	B30	R_PRSNT_N
A31	GND	B31	GND
A32	G2_RXP9	B32	G2_TXP9
A33	G2_RXN9	B33	G2_TXN9
A34	GND	B34	GND
A35	G2_RXP8	B35	G2_TXP8
A36	G2_RXN8	B36	G2_TXN8
A37	GND	B37	GND
75	NP_NC_1	76	NP_NC_2
77	PGND_1	78	PGND_3
79	PGND_2	80	PGND_4

## MCIO5 Pin Definition

Pin	Definition	Pin	Definition
A1	GND	B1	GND
A2	G1_RXP0	B2	G1_TXP0
A3	G1_RXN0	B3	G1_TXN0
A4	GND	B4	GND
A5	G1_RXP1	B5	G1_TXP1
A6	G1_RXN1	B6	G1_TXN1
A7	GND	B7	GND
A8	BP_TYPE	B8	SCL
A9	PCIE_WAKE#	B9	SDA
A10	GND	B10	GND
A11	DP	B11	BUF_RST0_L
A12	DN	B12	R_PRSNT_N
A13	GND	B13	GND
A14	G1_RXP2	B14	G1_TXP2
A15	G1_RXN2	B15	G1_TXN2
A16	GND	B16	GND
A17	G1_RXP3	B17	G1_TXP3
A18	G1_RXN3	B18	G1_TXN3
A19	GND	B19	GND
A20	G1_RXP4	B20	G1_TXP4
A21	G1_RXN4	B21	G1_TXN4
A22	GND	B22	GND
A23	G1_RXP5	B23	G1_TXP5
A24	G1_RXN5	B24	G1_TXN5
A25	GND	B25	GND
A26	BP_TYPE	B26	SCL
A27	PCIE_WAKE#	B27	SDA
A28	GND	B28	GND
A29	DP	B29	BUF_RST0_L
A30	DN	B30	R_PRSNT_N
A31	GND	B31	GND
A32	G1_RXP6	B32	G1_TXP6
A33	G1_RXN6	B33	G1_TXN6
A34	GND	B34	GND
A35	G1_RXP7	B35	G1_TXP7
A36	G1_RXN7	B36	G1_TXN7
A37	GND	B37	GND
75	NP_NC_1	76	NP_NC_2
77	PGND_1	78	PGND_3
79	PGND_2	80	PGND_4

## MCIO6 Pin Definition

Pin	Definition	Pin	Definition
A1	GND	B1	GND
A2	G1_RXP8	B2	G1_TXP8
A3	G1_RXN8	B3	G1_TXN8
A4	GND	B4	GND
A5	G1_RXP9	B5	G1_TXP9
A6	G1_RXN9	B6	G1_TXN9
A7	GND	B7	GND
A8	BP_TYPE	B8	SCL
A9	PCIE_WAKE#	B9	SDA
A10	GND	B10	GND
A11	DP	B11	BUF_RST0_L
A12	DN	B12	R_PRSENT_N
A13	GND	B13	GND
A14	G1_RXP10	B14	G1_TXP10
A15	G1_RXN10	B15	G1_TXN10
A16	GND	B16	GND
A17	G1_RXP11	B17	G1_TXP11
A18	G1_RXN11	B18	G1_TXN11
A19	GND	B19	GND
A20	G1_RXP12	B20	G1_TXP12
A21	G1_RXN12	B21	G1_TXN12
A22	GND	B22	GND
A23	G1_RXP13	B23	G1_TXP13
A24	G1_RXN13	B24	G1_TXN13
A25	GND	B25	GND
A26	BP_TYPE	B26	SCL
A27	PCIE_WAKE#	B27	SDA
A28	GND	B28	GND
A29	DP	B29	BUF_RST0_L
A30	DN	B30	R_PRSENT_N
A31	GND	B31	GND
A32	G1_RXP14	B32	G1_TXP14
A33	G1_RXN14	B33	G1_TXN14
A34	GND	B34	GND
A35	G1_RXP15	B35	G1_TXP15
A36	G1_RXN15	B36	G1_TXN15
A37	GND	B37	GND
75	NP_NC_1	76	NP_NC_2
77	PGND_1	78	PGND_3
79	PGND_2	80	PGND_4



## MCIO7 Pin Definition

Pin	Definition	Pin	Definition
A1	GND	B1	GND
A2	G0_RXP0	B2	G0_TXP0
A3	G0_RXN0	B3	G0_TXN0
A4	GND	B4	GND
A5	G0_RXP1	B5	G0_TXP1
A6	G0_RXN1	B6	G0_TXN1
A7	GND	B7	GND
A8	BP_TYPE	B8	SCL
A9	PCIE_WAKE#	B9	SDA
A10	GND	B10	GND
A11	DP	B11	BUF_RST0_L
A12	DN	B12	R_PRSNT_N
A13	GND	B13	GND
A14	G0_RXP2	B14	G0_TXP2
A15	G0_RXN2	B15	G0_TXN2
A16	GND	B16	GND
A17	G0_RXP3	B17	G0_TXP3
A18	G0_RXN3	B18	G0_TXN3
A19	GND	B19	GND
A20	G0_RXP4	B20	G0_TXP4
A21	G0_RXN4	B21	G0_TXN4
A22	GND	B22	GND
A23	G0_RXP5	B23	G0_TXP5
A24	G0_RXN5	B24	G0_TXN5
A25	GND	B25	GND
A26	BP_TYPE	B26	SCL
A27	PCIE_WAKE#	B27	SDA
A28	GND	B28	GND
A29	DP	B29	BUF_RST0_L
A30	DN	B30	R_PRSNT_N
A31	GND	B31	GND
A32	G0_RXP6	B32	G0_TXP6
A33	G0_RXN6	B33	G0_TXN6
A34	GND	B34	GND
A35	G0_RXP7	B35	G0_TXP7
A36	G0_RXN7	B36	G0_TXN7
A37	GND	B37	GND
75	NP_NC_1	76	NP_NC_2
77	PGND_1	78	PGND_3
79	PGND_2	80	PGND_4

## MCIO8 Pin Definition

Pin	Definition	Pin	Definition
A1	GND	B1	GND
A2	G0_RXP8	B2	G0_TXP8
A3	G0_RXN8	B3	G0_TXN8
A4	GND	B4	GND
A5	G0_RXP9	B5	G0_TXP9
A6	G0_RXN9	B6	G0_TXN9
A7	GND	B7	GND
A8	BP_TYPE	B8	SCL
A9	PCIE_WAKE#	B9	SDA
A10	GND	B10	GND
A11	DP	B11	BUF_RST0_L
A12	DN	B12	R_PRSNT_N
A13	GND	B13	GND
A14	G0_RXP10	B14	G0_TXP10
A15	G0_RXN10	B15	G0_TXN10
A16	GND	B16	GND
A17	G0_RXP11	B17	G0_TXP11
A18	G0_RXN11	B18	G0_TXN11
A19	GND	B19	GND
A20	G0_RXP12	B20	G0_TXP12
A21	G0_RXN12	B21	G0_TXN12
A22	GND	B22	GND
A23	G0_RXP13	B23	G0_TXP13
A24	G0_RXN13	B24	G0_TXN13
A25	GND	B25	GND
A26	BP_TYPE	B26	SCL
A27	PCIE_WAKE#	B27	SDA
A28	GND	B28	GND
A29	DP	B29	BUF_RST0_L
A30	DN	B30	R_PRSNT_N
A31	GND	B31	GND
A32	G0_RXP14	B32	G0_TXP14
A33	G0_RXN14	B33	G0_TXN14
A34	GND	B34	GND
A35	G0_RXP15	B35	G0_TXP15
A36	G0_RXN15	B36	G0_TXN15
A37	GND	B37	GND
75	NP_NC_1	76	NP_NC_2
77	PGND_1	78	PGND_3
79	PGND_2	80	PGND_4

## 2.8 Dr. Debug

Dr. Debug is used to provide code information, which makes troubleshooting even easier. Please see the diagrams below for reading the Dr. Debug codes.

Code	Description
0x10	PEI_CORE_STARTED
0x11	PEI_CAR_CPU_INIT
0x15	PEI_CAR_NB_INIT
0x19	PEI_CAR_SB_INIT
0x31	PEI_MEMORY_INSTALLED
0x32	PEI_CPU_INIT
0x33	PEI_CPU_CACHE_INIT
0x34	PEI_CPU_AP_INIT
0x35	PEI_CPU_BSP_SELECT
0x36	PEI_CPU_SMM_INIT
0x37	PEI_MEM_NB_INIT
0x3B	PEI_MEM_SB_INIT
0x4F	PEI_DXE_IPL_STARTED
0x60	DXE_CORE_STARTED
0x61	DXE_NVRAM_INIT
0x62	DXE_SBRUN_INIT

0x63	DXE_CPU_INIT
0x68	DXE_NB_HB_INIT
0x69	DXE_NB_INIT
0x6A	DXE_NB_SMM_INIT
0x70	DXE_SB_INIT
0x71	DXE_SB_SMM_INIT
0x72	DXE_SB_DEVICES_INIT
0x78	DXE_ACPI_INIT
0x79	DXE_CSM_INIT
0x90	DXE_BDS_STARTED
0x91	DXE_BDS_CONNECT_DRIVERS
0x92	DXE_PCI_BUS_BEGIN
0x93	DXE_PCI_BUS_HPC_INIT
0x94	DXE_PCI_BUS_ENUM
0x95	DXE_PCI_BUS_REQUEST_RESOURCES
0x96	DXE_PCI_BUS_ASSIGN_RESOURCES
0x97	DXE_CON_OUT_CONNECT
0x98	DXE_CON_IN_CONNECT

0x99	DXE_SIO_INIT
0x9A	DXE_USB_BEGIN
0x9B	DXE_USB_RESET
0x9C	DXE_USB_DETECT
0x9D	DXE_USB_ENABLE
0xA0	DXE_IDE_BEGIN
0xA1	DXE_IDE_RESET
0xA2	DXE_IDE_DETECT
0xA3	DXE_IDE_ENABLE
0xA4	DXE_SCSI_BEGIN
0xA5	DXE_SCSI_RESET
0xA6	DXE_SCSI_DETECT
0xA7	DXE_SCSI_ENABLE
0xA8	DXE_SETUP_VERIFYING_PASSWORD
0xA9	DXE_SETUP_START
0xAB	DXE_SETUP_INPUT_WAIT
0xAD	DXE_READY_TO_BOOT
0xAE	DXE_LEGACY_BOOT

0xAF	DXE_EXIT_BOOT_SERVICES
0xB0	RT_SET_VIRTUAL_ADDRESS_MAP_BEGIN
0xB1	RT_SET_VIRTUAL_ADDRESS_MAP_END
0xB2	DXE_LEGACY_OPROM_INIT
0xB3	DXE_RESET_SYSTEM
0xB4	DXE_USB_HOTPLUG
0xB5	DXE_PCI_BUS_HOTPLUG
0xB6	DXE_NVRAM_CLEANUP
0xB7	DXE_CONFIGURATION_RESET
0xF0	PEI_RECOVERY_AUTO
0xF1	PEI_RECOVERY_USER
0xF2	PEI_RECOVERY_STARTED
0xF3	PEI_RECOVERY_CAPSULE_FOUND
0xF4	PEI_RECOVERY_CAPSULE_LOADED
0xE0	PEI_S3_STARTED
0xE1	PEI_S3_BOOT_SCRIPT
0xE2	PEI_S3_VIDEO_REPOST

0xE3	PEI_S3_OS_WAKE
0x50	PEI_MEMORY_INVALID_TYPE
0x53	PEI_MEMORY_NOT_DETECTED
0x55	PEI_MEMORY_NOT_INSTALLED
0x57	PEI_CPU_MISMATCH
0x58	PEI_CPU_SELF_TEST_FAILED
0x59	PEI_CPU_NO_MICROCODE
0x5A	PEI_CPU_ERROR
0x5B	PEI_RESET_NOT_AVAILABLE
0xD0	DXE_CPU_ERROR
0xD1	DXE_NB_ERROR
0xD2	DXE_SB_ERROR
0xD3	DXE_ARCH_PROTOCOL_NOT_AVAILABLE
0xD4	DXE_PCI_BUS_OUT_OF_RESOURCES
0xD5	DXE_LEGACY_OPROM_NO_SPACE
0xD6	DXE_NO_CON_OUT
0xD7	DXE_NO_CON_IN

0xD8	DXE_INVALID_PASSWORD
0xD9	DXE_BOOT_OPTION_LOAD_ERROR
0xDA	DXE_BOOT_OPTION_FAILED
0xDB	DXE_FLASH_UPDATE_FAILED
0xDC	DXE_RESET_NOT_AVAILABLE
0xE8	PEI_MEMORY_S3_RESUME_FAILED
0xE9	PEI_S3_RESUME_PPI_NOT_FOUND
0xEA	PEI_S3_BOOT_SCRIPT_ERROR
0xEB	PEI_S3_OS_WAKE_ERROR



## 2.9 Identification purpose LED/Switch

With the UID button, locate the server working on from behind a rack of servers.

Unit Identification  
purpose LED/Switch  
(UID1)



When the UID button on the front or rear panel is pressed, the front/rear UID blue LED indicator will be turned on. Press the UID button again to turn off the indicator.

## 2.10 Dual LAN and Teaming Operation Guide

Dual LAN with Teaming enabled on this motherboard allows two single connections to act as one single connection(s) for twice the transmission bandwidth, making data transmission more effective and improving the quality of transmission of distant images. Fault tolerance on the dual LAN network prevents network downtime by transferring the workload from a failed port to a working port.



*The speed of transmission is subject to the actual network environment or status even with Teaming enabled.*

Before setting up Teaming, please make sure whether the Switch (or Router) supports Teaming (IEEE 802.3ad Link Aggregation). It can be specified a preferred adapter in Intel PROSet. Under normal conditions, the Primary adapter handles all non-TCP/IP traffic. The Secondary adapter will receive fallback traffic if the primary fails. If the Preferred Primary adapter fails, but is later restored to an active status, control is automatically switched back to the Preferred Primary adapter.

### **Step 1**

From **Device Manager**, open the properties of a team.

### **Step 2**

Click the **Settings** tab.

### **Step 3**

Click the **Modify Team** button.

### **Step 4**

Select the adapter that want to be the primary adapter and click the **Set Primary** button.

If not specify a preferred primary adapter, the software will choose an adapter of the highest capability (model and speed) to act as the default primary. When a failover occurs, another adapter becomes the primary. The adapter will, however, rejoin the team as a non-primary.

## 2.11 M.2 SSD Module Installation Guide

The Hyper M.2 Socket (M2\_1/M2\_2, Key M) supports type 2260/2280/22110 M.2 PCI Express module up to Gen5 x4 (32GT/s x4).

### Installing the M.2 SSD Module

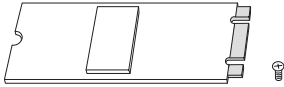

#### Step 1

Prepare a M.2 SSD module and the screw.

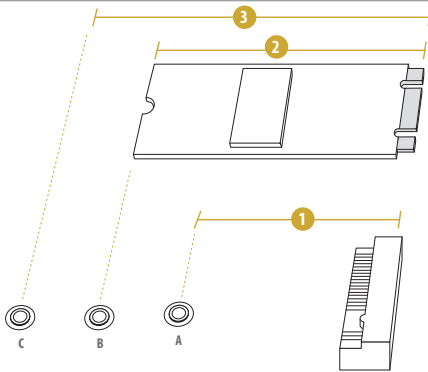

#### Step 2

Depending on the PCB type and length of the M.2 SSD module, find the corresponding nut location to be used.

M2_1:	No.	1	2	3
Nut Location		A (NUT60_2)	B (NUT80_2)	C (NUT110_2)
PCB Length		6cm	8cm	11cm
Module Type		Type 2260	Type 2280	Type 22110

M2_2:	No.	1	2	3
Nut Location		A (NUT60_1)	B (NUT80_1)	C (NUT110_1)
PCB Length		6cm	8cm	11cm
Module Type		Type 2260	Type 2280	Type 22110

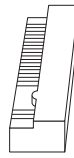

### Step 3

Move the standoff based on the module type and length. Skip Step 3 and 4 and go straight to Step 5 when using the default nut. Otherwise, release the standoff by hand.

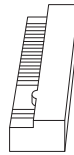

### Step 4

Peel off the yellow protective film on the nut to be used. Hand tighten the standoff into the desired nut location on the motherboard.

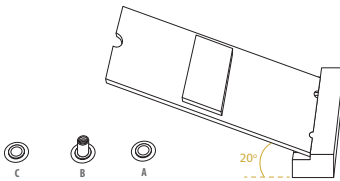
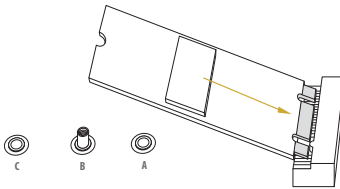

### Step 5

Align and gently insert the M.2 SSD module into the M.2 slot. Please be aware that the M.2 SSD module only fits in one orientation.

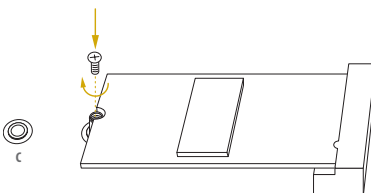

### Step 6

Tighten the screw with a screwdriver to secure the module into place. Please do not overtighten the screw as this might damage the module.

## Chapter 3 UEFI Setup Utility

### 3.1 Introduction

This section explains how to use the UEFI SETUP UTILITY to configure the system. The UEFI chip on the motherboard stores the UEFI SETUP UTILITY. Run the UEFI SETUP UTILITY when starting up the computer. Please press <F2> or <Del> during the Power-On-Self-Test (POST) to enter the UEFI SETUP UTILITY; otherwise, POST will continue with its test routines.

Restart the system by pressing <Ctrl> + <Alt> + <Delete> to enter the UEFI SETUP UTILITY after POST, or by pressing the reset button on the system chassis. It can also allow user to restart by turning the system off and then back on.



*Because the UEFI software is constantly being updated, the following UEFI setup screens and descriptions are for reference purpose only.*

#### 3.1.1 UEFI Menu Bar

The top of the screen has a menu bar with the following selections:

Item	Description
Main	To set up the system time/date information
Advanced	To set up the advanced UEFI features
Security	To set up the security features
Server Mgmt	To manage the server
Event Logs	For event log configuration
Boot	To set up the default system device to locate and load the Operating System
Exit	To exit the current screen or the UEFI SETUP UTILITY

Use <←> key or <→> key to choose among the selections on the menu bar, and then press <Enter> to get into the sub screen.

### 3.1.2 Navigation Keys

Please check the following table for the function description of each navigation key.

Navigation Key(s)	Function Description
← / →	Moves cursor left or right to select Screens
↑ / ↓	Moves cursor up or down to select items
+ / -	To change option for the selected items
<Tab>	Switch to next function
<Enter>	To bring up the selected screen
<PGUP>	Go to the previous page
<PGDN>	Go to the next page
<HOME>	Go to the top of the screen
<END>	Go to the bottom of the screen
<F1>	To display the General Help Screen
<F7>	Discard changes and exit the UEFI SETUP UTILITY
<F9>	Load optimal default values for all the settings
<F10>	Save changes and exit the UEFI SETUP UTILITY
<F12>	Print screen
<ESC>	Jump to the Exit Screen or exit the current screen

## 3.2 Main Screen

Once entering the UEFI SETUP UTILITY, the Main screen will appear and display the system overview. The Main screen provides system overview information and allows user to set the system time and date.



### Motherboard Information

Enter this item to view the motherboard information.

### Processor Information

Enter this item to view the processor information.

### Memory Information

Enter this item to view the memory information.

*Note: The screenshots in this user manual are examples and for references only. The actual images may slightly vary depending on the model and the version using.*

## 3.2.1 Motherboard Information

Press [Enter] to view the information of the motherboard.

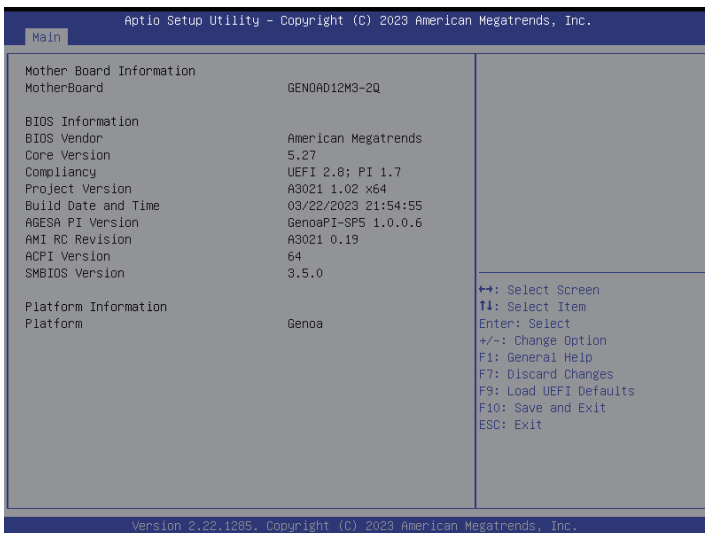

## 3.2.2 Processor Information

Press [Enter] to view the information of the processor.

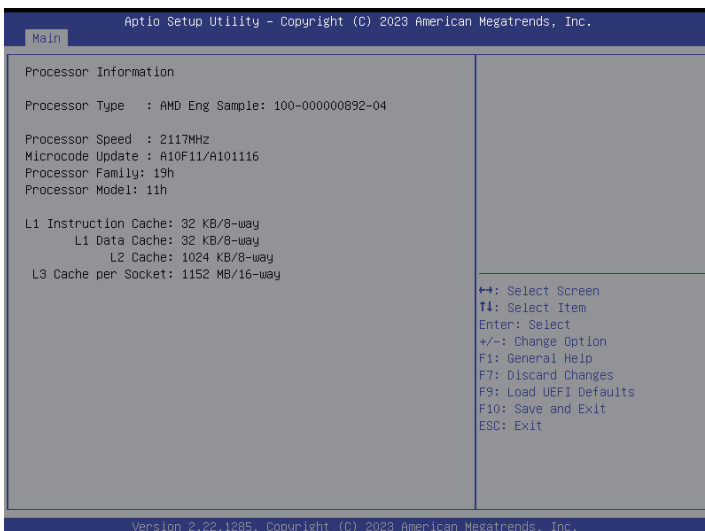



### 3.2.3 Memory Information

Press [Enter] to view the information of the memory.

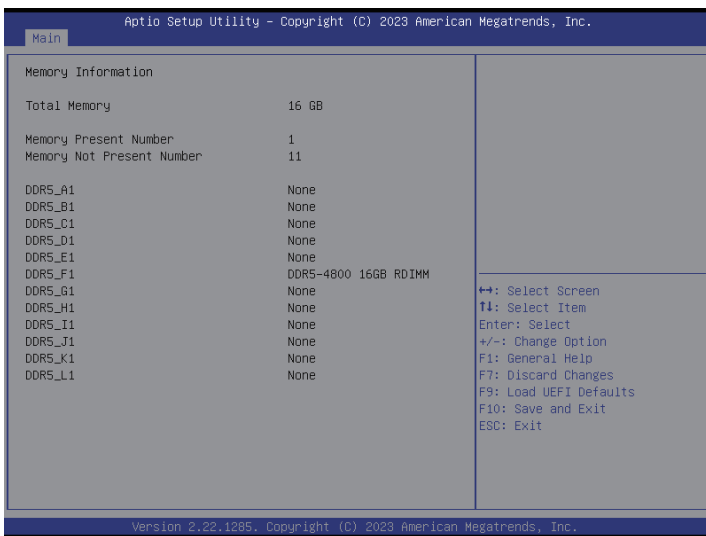

### 3.3 Advanced Screen

This section allowed to configure the following items: CPU Configuration, Chipset Configuration, Storage Configuration, NVMe Configuration, ACPI Configuration, USB Configuration, Super IO Configuration, Serial Port Console Redirection, H/W Monitor, PCI Subsystem Settings, AMD CBS, AMD PBS, PSP Firmware Versions, Network Stack Configuration, Driver Health, Tls Auth Configuration and Instant Flash.

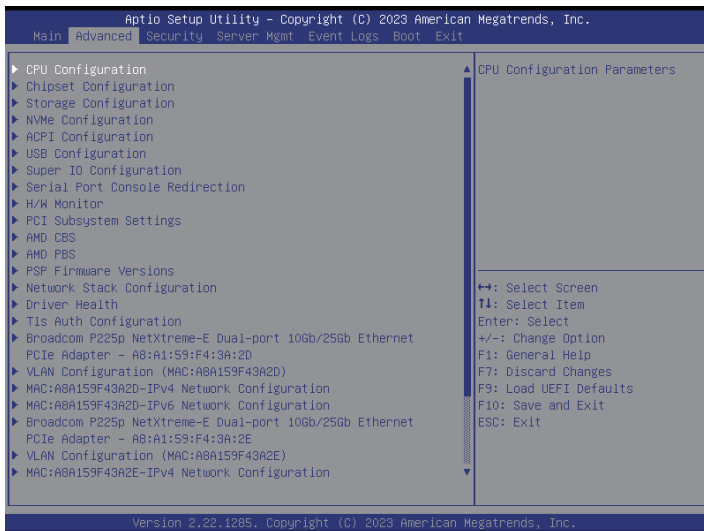

Setting wrong values in this section may cause the system to malfunction.

### 3.3.1 CPU Configuration



#### SVM Mode

Enable or disable CPU Virtualization.

## 3.3.2 Chipset Configuration

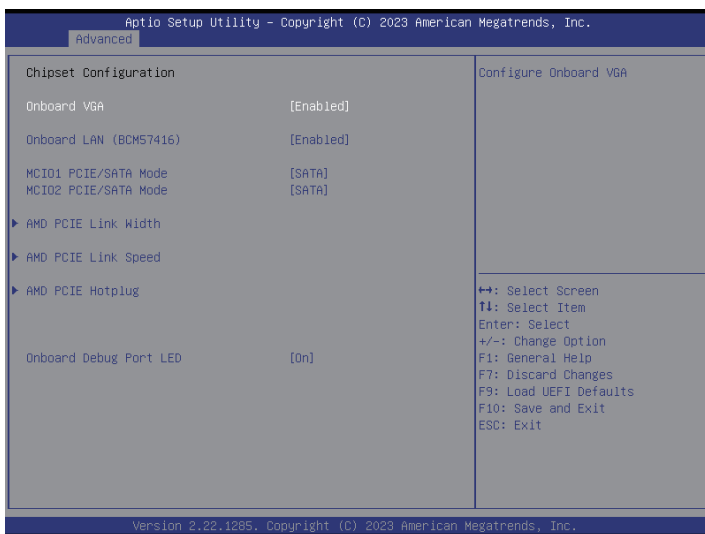

### Onboard VGA

Use this to enable or disable the Onboard VGA function.

### Onboard LAN (BCM57416)

Use this item to enable or disable Onboard LAN.

### MCIO1 PCIE/SATA Mode

Configure MCIO1 PCIE/SATA Mode.

### MCIO2 PCIE/SATA Mode

Configure MCIO2 PCIE/SATA Mode.

### AMD PCIE Link Width

Use this item to configure PCIE Link Width.

### PCIE6/7 Link Width-

Use this item to select PCIE6/7 Link Width.

### OCP3 Link Width-

Use this item to select OCP Link Width.

### MCIO3/4/5/6/7/8 Link Width

Use this item to select MCIO3/4/5/6/7/8 Link Width.

### AMD PCIE Link Speed

Use this item to configure PCIE Slot Speed.

### MCIO3/4/5/6/7/8 Link Speed

Use this item to select MCIO Link Speed. The default value is [Auto].

### AMD PCIE Hotplug

Use this item to configure PCIE Hot Plug.

### PCIE6/7, OCP3, M2\_1, M2\_2, MCIO13/4/5/6/7/8 Hotplug

Use this item to enable or disable PCIE6/7, OCP3, M2\_1, M2\_2, MCIO3/4/5/6/7/8 Hotplug.

### Onboard Debug Port LED

Use this item to enable or disable the onboard Dr. Debug LED.

### 3.3.3 Storage Configuration

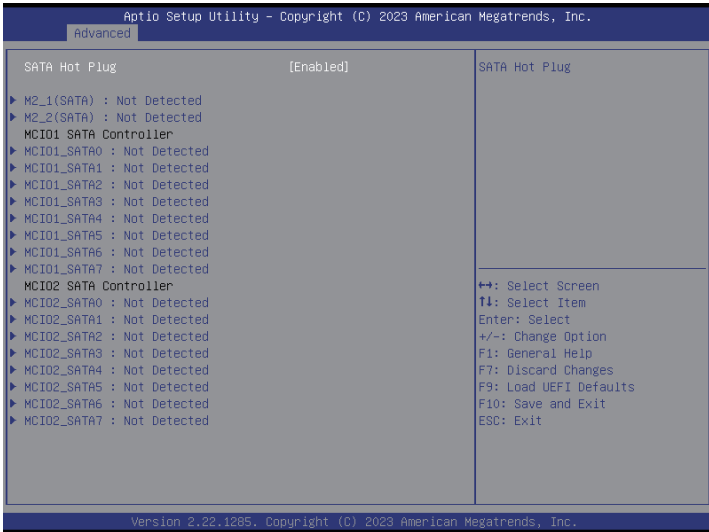

#### SATA Hot Plug

Enable or disable the SATA Hot Plug Function.

### 3.3.4 NVMe Configuration

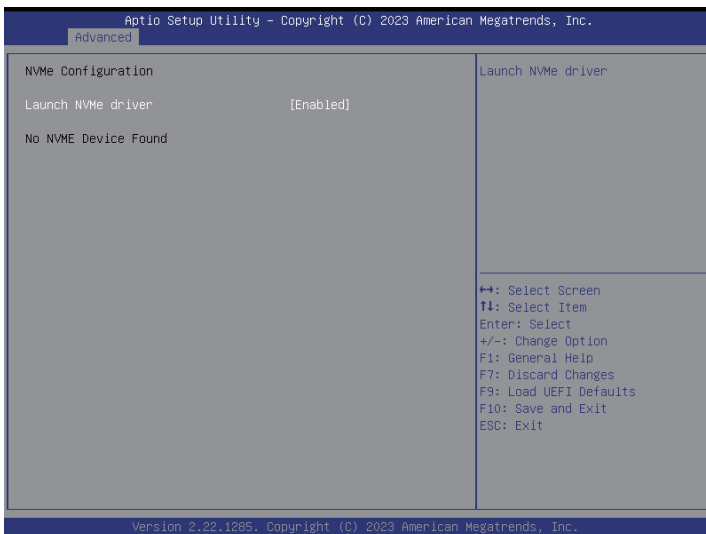

The NVMe Configuration displays the NVMe controller and Drive information.

#### Launch NVMe driver

Select this item to enable or disable launch NVMe driver.

### 3.3.5 ACPI Configuration

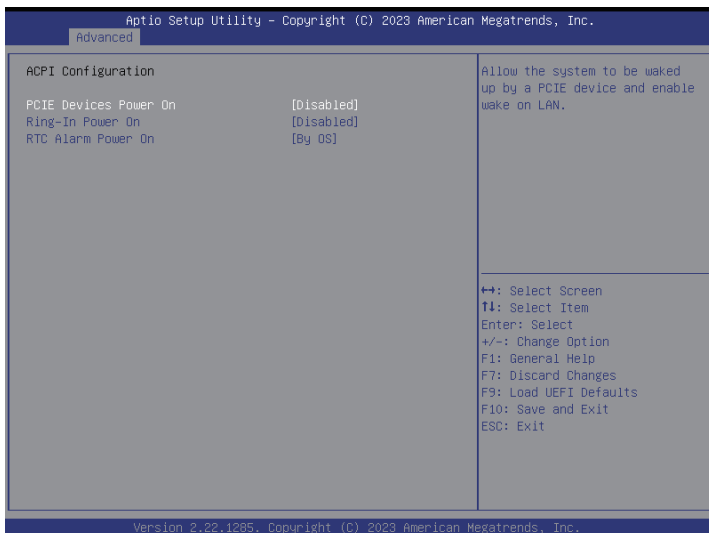

#### PCIE Devices Power On

Allow the system to be waked up by a PCIE device and enable wake on LAN.

#### Ring-In Power On

Use this item to enable or disable Ring-In signals to turn on the system from the power-soft-off mode.

#### RTC Alarm Power On

Allow the system to be waked up by the real time clock alarm. Set it to By OS to let it be handled by the operating system.



### 3.3.6 USB Configuration

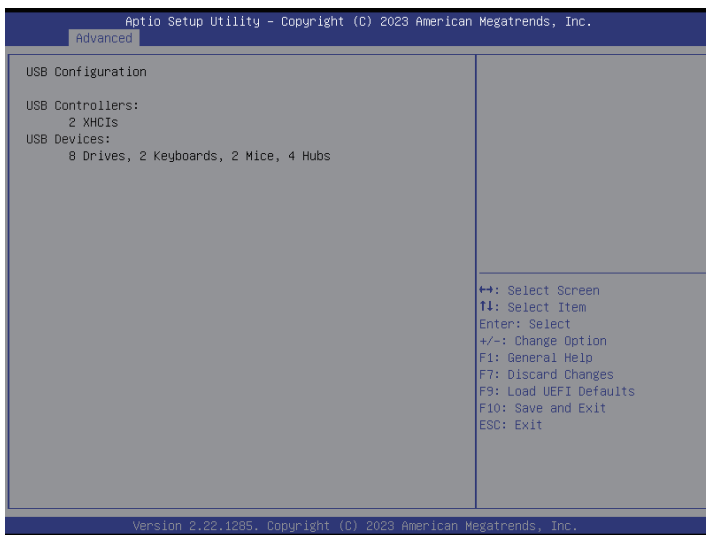

The USB Configuration displays the USB Controllers and USB Devices informations.

## 3.3.7 Super IO Configuration

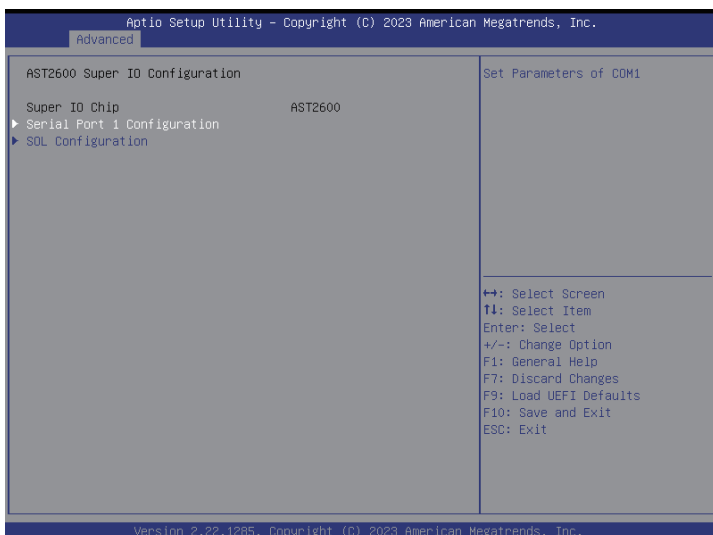

### Serial Port 1 Configuration

Use this item to set parameters of Serial Port 1 (COM1).

#### **Serial Port**

Use this item to enable or disable the serial port.

#### **Change Settings**

Use this item to select an optimal setting for Super IO device.

### SOL Configuration

Use this item to set parameters of SOL.

#### **SOL Port**

Use this item to set parameters of SOL.

### 3.3.8 Serial Port Console Redirection

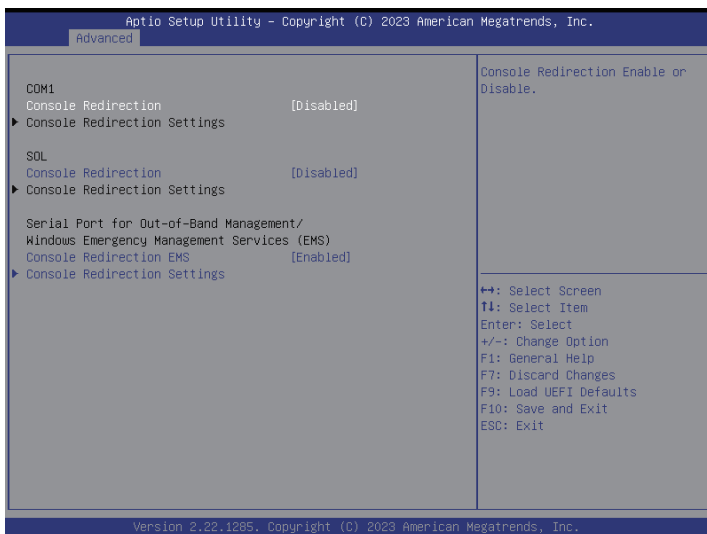

#### COM1 / SOL

#### Console Redirection

Use this option to enable or disable Console Redirection. If this item is set to Enabled that specifies a COM Port can be used for Console Redirection.

#### Console Redirection Settings

Use this option to configure Console Redirection Settings, and specify how the host computer and the remote computer (which are be connected to) will exchange data. Both computers should have the same or compatible settings.

#### Terminal Type

Use this item to select the preferred terminal emulation type for out-of-band management. It is recommended to select [VT-UTF8].

Option	Description
VT100	ASCII character set
VT100Plus	Extended VT100 that supports color and function keys
VT-UTF8	UTF8 encoding is used to map Unicode chars onto 1 or more bytes
ANSI	Extended ASCII character set

### **Bits Per Second**

Use this item to select the serial port transmission speed. The speed used in the host computer and the client computer must be the same. Long or noisy lines may require lower transmission speed. The options include [9600], [19200], [38400], [57600] and [115200].

### **Data Bits**

Use this item to set the data transmission size. The options include [7] and [8] (Bits).

### **Parity**

Use this item to select the parity bit. The options include [None], [Even], [Odd], [Mark] and [Space].

### **Stop Bits**

The item indicates the end of a serial data packet. The standard setting is [1] Stop Bit. Select [2] Stop Bits for slower devices.

### **Flow Control**

Use this item to set the flow control to prevent data loss from buffer overflow. When sending data, if the receiving buffers are full, a "stop" signal can be sent to stop the data flow. Once the buffers are empty, a "start" signal can be sent to restart the flow. Hardware flow uses two wires to send start/stop signals. The options include [None] and [Hardware RTS/CTS].

### **VT-UTF8 Combo Key Support**

Use this item to enable or disable the VT-UTF8 Combo Key Support for ANSI/VT100 terminals.

### **Recorder Mode**

Use this item to enable or disable Recorder Mode to capture terminal data and send it as text messages.

### **Resolution 100x31**

Use this item to enable or disable extended terminal resolution support.

### **Putty Keypad**

Use this item to select Function Key and Keypad on Putty.

## **Serial Port for Out-of-Band Management/Windows Emergency Management Services (EMS)**

### **Console Redirection EMS**

Use this option to enable or disable Console Redirection. Set this item to Enabled to select a COM Port to be used for Console Redirection.

### **Console Redirection Settings**

Use this option to configure Console Redirection Settings, and specify how the host computer and the remote computer (which are be connected to) will exchange data.

### Out-of-Band Mgmt Port

Microsoft Windows Emergency Management Services (EMS) allows for remote management of a Windows Server OS through a serial port.

### Terminal Type EMS

Use this item to select the preferred terminal emulation type for out-of-band management. It is recommended to select [VT-UTF8].

Option	Description
VT100	ASCII character set
VT100+	Extended VT100 that supports color and function keys
VT-UTF8	UTF8 encoding is used to map Unicode chars onto 1 or more bytes
ANSI	Extended ASCII character set

### Bits Per Second EMS

Use this item to select the serial port transmission speed. The speed used in the host computer and the client computer must be the same. Long or noisy lines may require lower transmission speed. The options include [9600], [19200], [57600] and [115200].

### Flow Control EMS

Use this item to set the flow control to prevent data loss from buffer overflow. When sending data, if the receiving buffers are full, a "stop" signal can be sent to stop the data flow. Once the buffers are empty, a "start" signal can be sent to restart the flow. Hardware flow uses two wires to send start/stop signals. The options include [None], [Hardware RTS/CTS], and [Software Xon/Xoff].

### Data Bits EMS

### Parity EMS

### Stop Bits EMS

### 3.3.9 H/W Monitor

In this section, it allows to monitor the status of the hardware on the system, including the parameters of the CPU temperature, motherboard temperature, CPU fan speed, chassis fan speed, and the critical voltage.

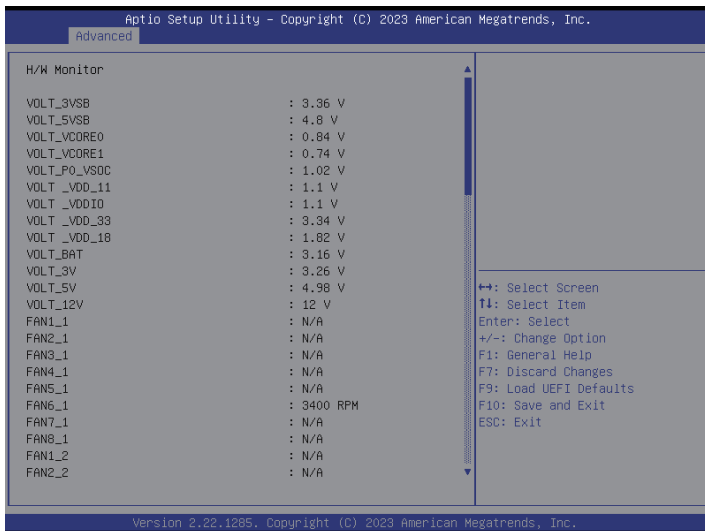

### 3.3.10 PCI Subsystem Settings

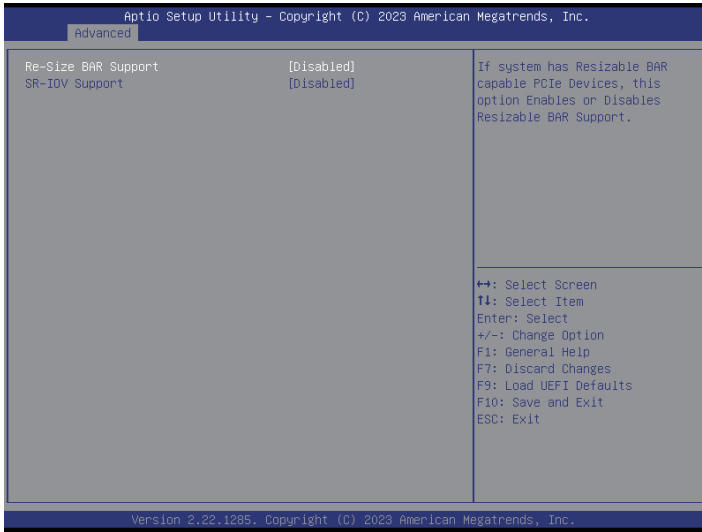

#### Re-Size BAR Support

If system has Resizable BAR capable PCIe Devices, this option enables or disables Resizable BAR support.

#### SR-IOV Support

If system has SR-IOV capable PCIe Devices, this option enables or disables Single Root IO Virtualization Support.

## 3.3.11 AMD CBS

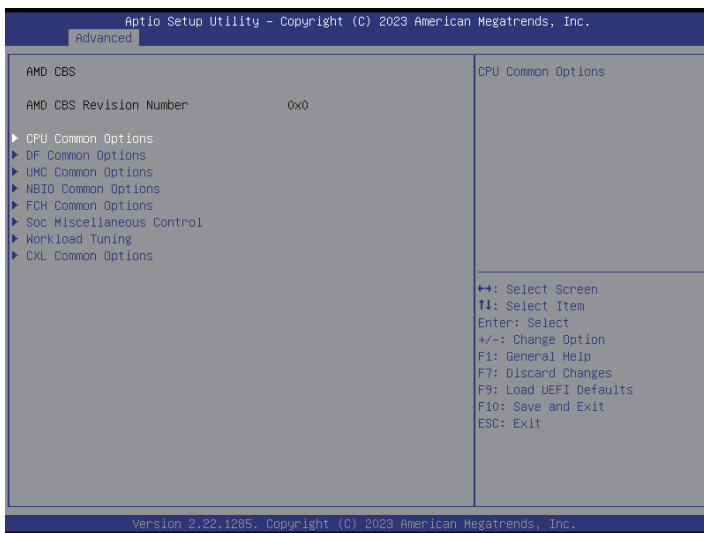

### CPU Common Options

Use this item to configure CPU Common options.

### DF Common Options

Use this item to configure DF Common options.

### UMC Common Options

Use this item to configure UMC Common options.

### NBIO Common Options

Use this item to configure NBIO Common options.

### FCH Common Options

Use this item to configure FCH Common options.

### Soc Miscellaneous Control

Use this item to configure Soc Miscellaneous Control options.

### Workload Tuning Options

Use this item to configure Workload Tuning options.

### CXL Common Options

Use this item to configure CXL Common options.



### 3.3.12 AMD PBS

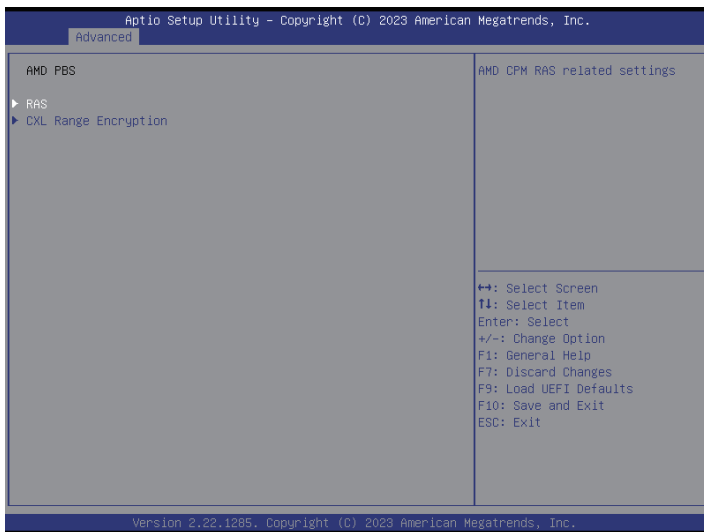

#### RAS

Use this item to configure AMD CPM RAS related settings.

#### **RAS Periodic SMI Control**

Use this to enable or disable Periodic SMI for polling [MCA Threshold] error.

#### **SMI Threshold**

This limits the number of [MCA Threshold and Deferred Error SMI source] per a unit time.

#### **SMI Scale**

Use this to defines the time scale.

#### **SMI Scale Unit**

Use this to defines the unit of time scale.

#### **SMI Period**

Use this to defines the polling interval with ms unit. Input 0 value to disable this function.

#### **GHEs Notify Type**

This specifies the notification type for deferred/corrected errors.

#### **GHEs UnCorr Notify Type**

This specifies the notification type for uncorrected errors.

#### **PCIe GHEs Notify Type**

This specifies the notification type for PCIe corrected errors.

**PCIe UnCorr GHES Notify Type**

This specifies the notification type for PCIe uncorrected errors.

**PCIe Root Port Corr Err Mask Reg**

Use this to initialize the PCIe AER corrected error mask register of root port.

**PCIe Root Port UnCorr Err Mask Reg**

Use this to initialize the PCIe AER uncorrected error mask register of root port.

**PCIe Root Port UnCorr Err Sev Reg**

Use this to initialize the PCIe AER uncorrected error severity registers of root port.

**PCIe Device Corr Err Mask Reg**

Use this to initialize the PCIe AER corrected error mask register of PCIe device.

**PCIe Device UnCorr Err Mask Reg**

Use this to initialize the PCIe AER uncorrected error mask register of PCIe device.

**PCIe Device UnCorr Error Sev Reg**

Use this to initialize the PCIe AER uncorrected error severity registers of PCIe device

**CXL DP CIE Mask Enable**

Use this to enable or disable masking of CXL DP correctable error-internal error.

**DRAM Hard Post Package Repair**

Use this to enable or disable the spare DRAM rows to replace malfunctioning rows via an in-field repair mechanism.

**HEST DMC Structure Support**

Use this to enable or disable HEST DMC Structure feature.

**CXL Error Report Support**

Use this to enable or disable CXL Error Report feature.

**CXL Range Encryption**

Use this item to configure AMD CXL Range Encryption related settings.

**Range1~7 Memory Base/Limit**

Use this to enter memory range base address and limit address.

**Start CXL Range Encryption**

Select this item to start and encrypt all memory ranges.

### 3.3.13 PSP Firmware Versions

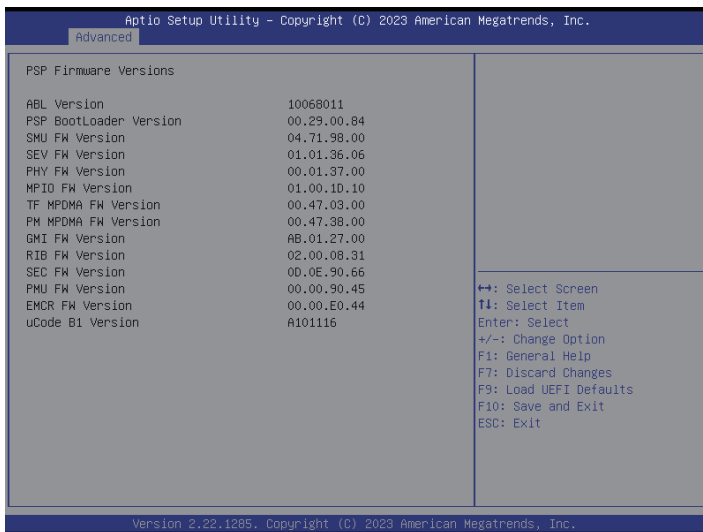

The PSP Firmware Versions displays the version information of ABL, PSP BootLoader, SMU FW, SEV FW, PHY FW, MPIO FW, TF MPDMA FW, PM MPDMA FW, GMI FW, RIB FW, SEC FW, PMU FW, EMCR FW and uCode B1.

## 3.3.14 Network Stack Configuration



### Network Stack

Use this item to enable or disable UEFI Network Stack.

### IPv4 PXE Support

Use this item to enable or disable IPv4 PXE boot support. If disabled, IPv4 PXE boot support will not be available.

### IPv4 HTTP Support

Use this item to enable or disable IPv4 HTTP boot support. If disabled, IPv4 HTTP boot support will not be available.

### IPv6 PXE Support

Use this item to enable or disable IPv6 PXE boot support. If disabled, IPv6 PXE boot support will not be available.

### IPv6 HTTP Support

Use this item to enable or disable IPv6 HTTP boot support. If disabled, IPv6 HTTP boot support will not be available.

### PXE boot wait time

Wait time in seconds to press ESC key to abort the PXE boot. Use either +/- or numeric keys to set the value.

## Media detect count

Number of times the presence of media will be checked. Use either +/- or numeric keys to set the value.

### 3.3.15 Driver Health

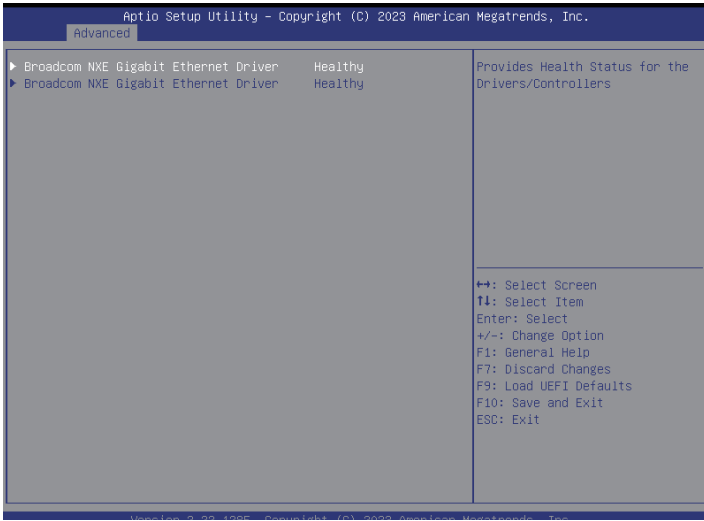

#### Broadcom NXE Gigabit Ethernet Driver

Provides Health Status for the Drivers/Controllers.

#### Broadcom NXE Gigabit Ethernet Driver

Provides Health Status for the Drivers/Controllers

### 3.3.16 Tls Auth Configuration

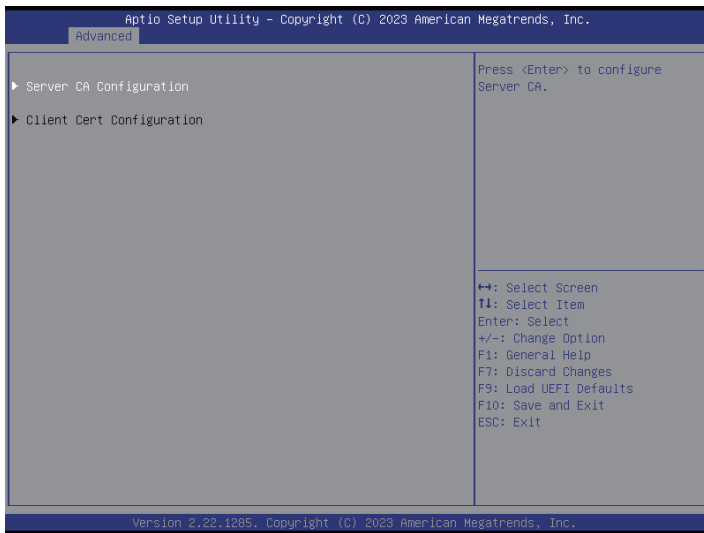

#### Server CA Configuration

Press <Enter> to configure Server CA.

#### **Enroll Cert**

Press <Enter> to enroll cert.

#### **Delete Cert**

Press <Enter> to delete cert.

#### Client Cert Configuration

Press <Enter> to configure Client Cert.

### 3.3.17 Instant Flash

Instant Flash is a UEFI flash utility embedded in Flash ROM. This convenient UEFI update tool allows user to update system UEFI without entering operating systems first like MS-DOS or Windows. Just save the new UEFI file to the USB flash drive, floppy disk or hard drive and launch this tool, then update the UEFI only in a few clicks without preparing an additional floppy diskette or other complicated flash utility. Please be noted that the USB flash drive or hard drive must use FAT32/16/12 file system. The utility will show the UEFI files and the respective information when executing Instant Flash utility. Select the proper UEFI file to update the UEFI, and reboot the system after the UEFI update process is completed.



## 3.4 Security

In this section, set or change the supervisor/user password for the system. For the user password, it also allows to clear it.

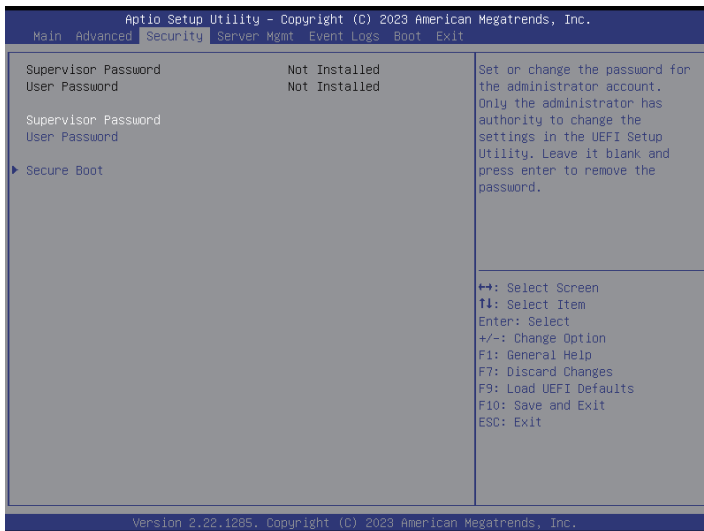

### Supervisor Password

Set or change the password for the administrator account. Only the administrator has authority to change the settings in the UEFI Setup Utility. Leave it blank and press enter to remove the password.

### User Password

Set or change the password for the user account. Users are unable to change the settings in the UEFI Setup Utility. Leave it blank and press enter to remove the password.

### Secure Boot

Use this to enable or disable Secure Boot Control. The default value is [Disabled]. Enable to support Windows Server 2012 R2 or later versions Secure Boot.

### Secure Boot Mode

Secure Boot mode selector: Standard/Custom. In Custom mode Secure Boot Variables can be configured without authentication.

### Install Default Secure Boot Keys

Please install default secure boot keys if it's the first time using secure boot.

## 3.4.1 Key Management

In this section, expert user can modify Secure Boot Policy variables without full authentication.

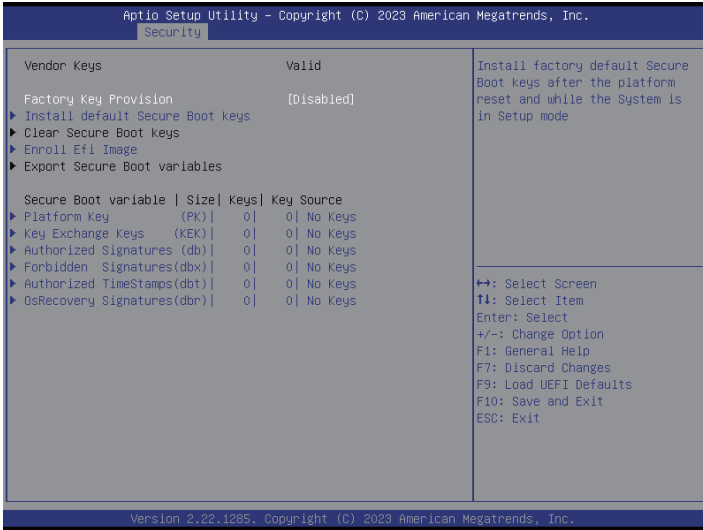

### Factory Key Provision

Install factory default Secure Boot keys after the platform reset and while the System is in Setup mode.

### Install Default Secure Boot Keys

Please install default secure boot keys if it's the first time to use the secure boot.

### Enroll Efi Image

Allow the image to run in Secure Boot mode. Enroll SHA256 hash of the binary into Authorized Signature Database (db).

### Platform Key(PK)

Enroll Factory Defaults or load certificates from a file:

1. Public Key Certificate in:

- a) EFI\_SIGNATURE\_LIST
- b) EFI\_CERT\_X509 (DER)

c) EFI\_CERT\_RSA2048 (bin)

d) EFI\_CERT\_SHAXXX

2. Authenticated UEFI Variable

3. EFI PE/COFF Image(SHA256)

Key Source: Factory, External, Mixed

### Key Exchange Keys(KEK)

Enroll Factory Defaults or load certificates from a file:

1. Public Key Certificate in:

a) EFI\_SIGNATURE\_LIST

b) EFI\_CERT\_X509 (DER)

c) EFI\_CERT\_RSA2048 (bin)

d) EFI\_CERT\_SHAXXX

2. Authenticated UEFI Variable

3. EFI PE/COFF Image(SHA256)

Key Source: Factory, External, Mixed

### Authorized Signatures(db)

Enroll Factory Defaults or load certificates from a file:

1. Public Key Certificate in:

a) EFI\_SIGNATURE\_LIST

b) EFI\_CERT\_X509 (DER)

c) EFI\_CERT\_RSA2048 (bin)

d) EFI\_CERT\_SHAXXX

2. Authenticated UEFI Variable

3. EFI PE/COFF Image(SHA256)

Key Source: Factory, External, Mixed

### Forbidden Signatures(dbx)

Enroll Factory Defaults or load certificates from a file:

1. Public Key Certificate in:

- a) EFI\_SIGNATURE\_LIST
  - b) EFI\_CERT\_X509 (DER)
  - c) EFI\_CERT\_RSA2048 (bin)
  - d) EFI\_CERT\_SHAXXX
2. Authenticated UEFI Variable
  3. EFI PE/COFF Image(SHA256)

Key Source: Factory, External, Mixed

### Authorized TimeStamps(dbt)

Enroll Factory Defaults or load certificates from a file:

1. Public Key Certificate in:
  - a) EFI\_SIGNATURE\_LIST
  - b) EFI\_CERT\_X509 (DER)
  - c) EFI\_CERT\_RSA2048 (bin)
  - d) EFI\_CERT\_SHAXXX
2. Authenticated UEFI Variable
3. EFI PE/COFF Image(SHA256)

Key Source: Factory, External, Mixed

### OsRecovery Signatures(dbr)

Enroll Factory Defaults or load certificates from a file:

1. Public Key Certificate in:
  - a) EFI\_SIGNATURE\_LIST
  - b) EFI\_CERT\_X509 (DER)
  - c) EFI\_CERT\_RSA2048 (bin)
  - d) EFI\_CERT\_SHAXXX
2. Authenticated UEFI Variable
3. EFI PE/COFF Image(SHA256)

Key Source: Factory, External, Mixed

## 3.5 Server Mgmt

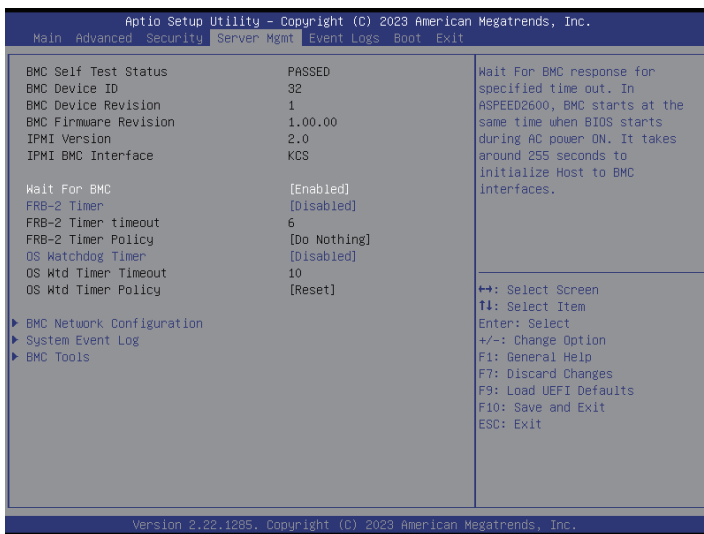

### Wait For BMC

Wait For BMC response for specified time out. BMC starts at the same time when BIOS starts during AC power ON. It takes around 255 seconds to initialize Host to BMC interfaces.

### FRB-2 Timer

Select this item to enable or disable FRB-2 timer (POST timer)

### FRB-2 Timer Timeout

Select this item to define the FRB-2 Time Expiration between 1 to 30 value.

### FRB-2 Timer Policy

Configure how the system should respond. If the FRB-2 Timer expires is disabled, this item is not available.

### OS Watchdog Timer

Select this item to enable or disable OS Watchdog Timer. If enabled, starts a BIOS timer which can only be shut off by Management Software after the OS loads.

### OS Wtd Timer Timeout

Configure the OS Boot Watchdog Timer Expiration between 1 to 30 min value. If the OS Boot Watchdog Timer is disabled, this item is not available.

## OS Wtd Timer Policy

Configure how the system should respond if the OS Boot Watchdog Timer expires. If the OS Boot Watchdog Timer is disabled, this item is not available.

## BMC Network Configuration

Select this item to configure BMC network parameters.

## System Event Log

Press <Enter> to change the SEL event log configuration.

## BMC Tools

Select this item to configure about KCS control, restore AC power loss and load BMC default settings.

## 3.5.1 BMC Network Configuration

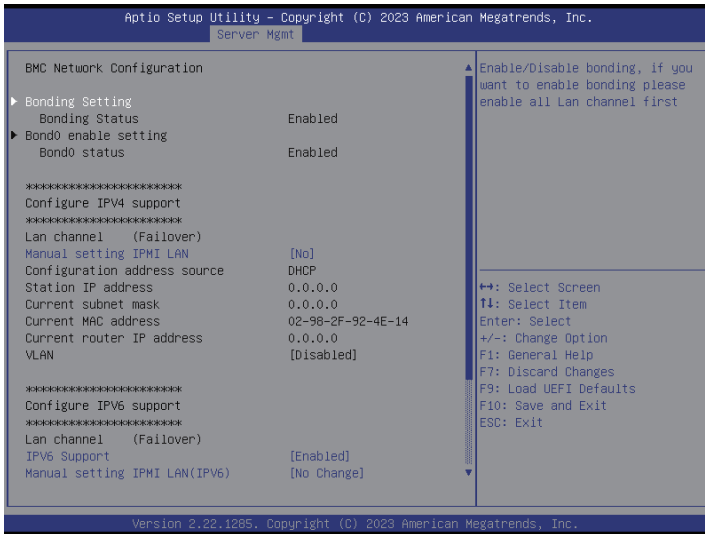

### Bonding Setting

Use this item to enable or disable bonding. Set this item to enable bonding please enable all Lan channel first.

### Bond0 Enable Setting

Show the Bond0 status is enabled or disabled.

### Manual Setting IPMI LAN

If [No] is selected, the IP address is assigned by DHCP. If using a static IP address, toggle to [Yes], and the changes take effect after the system reboots. The default value is [No].

### Configuration Address Source

Select to configure BMC network parameters statically or dynamically (by BIOS or BMC). Configuration options: [Static] and [DHCP].

**Static:** Manually enter the IP Address, Subnet Mask and Gateway Address in the BIOS for BMC LAN channel configuration.

**DHCP:** IP address, Subnet Mask and Gateway Address are automatically assigned by the network's DHCP server.



When [DHCP] or [Static] is selected, do NOT modify the BMC network settings on the IPMI web page.



*The default login information for the IPMI web interface is:*

*Username: admin*

*Password: admin*

*For more instructions on how to set up remote control environment and use the IPMI management platform, please refer to the IPMI Configuration User Guide or go to the Support website at: <http://www.asrockrack.com/support/ipmi.asp>*

## VLAN

Enabled/Disabled Virtual Local Area Network.

If [Enabled] is selected, configure the items below.

### IPV6 Support

Enable or disable LAN1 IPV6 Support.

### Manual Setting IPMI LAN (IPV6)

Select to configure LAN channel parameters statically or dynamically (by BIOS or BMC).

Unspecified option will not modify any BMC network parameters during BIOS phase.

### IPV6 Index

Set Selector for Static IP, range: 0 to 15.



## 3.5.2 System Event Log



### SEL Components

Change this to enable or disable event logging for error/progress codes during boot.

### Erase SEL

Use this to choose options for erasing SEL.

### When SEL is Full

Use this to choose options for reactions to a full SEL.

### Log EFI Status Codes

Use this item to disable the logging of EFI Status Codes or log only error code or only progress code or both.

### PCIe Device Degrade Elog Support

Use this item to enable or disable PCIe Device Degrade Error Logging Support.

### 3.5.3 BMC Tools

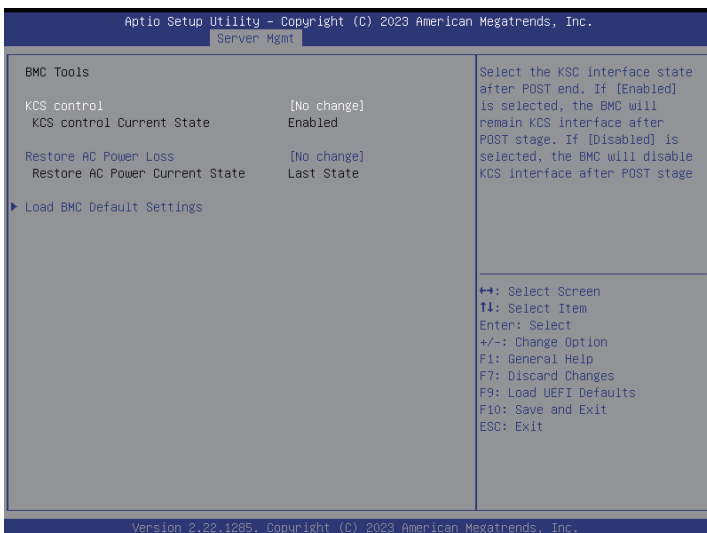

#### KCS control

Select the KCS interface state after POST end. If [Enabled] is selected, the BMC will remain KCS interface after POST stage. If [Disabled] is selected, the BMC will disable KCS interface after POST stage.

#### Restore AC Power Loss

This allows user to set the power state after an unexpected AC/power loss. If [Power Off] is selected, the AC/power remains off when the power recovers. If [Power On] is selected, the AC/power resumes and the system starts to boot up when the power recovers. If [Last State] is selected, it will recover to the state before AC/power loss.

#### Load BMC Default Settings

Use this item to load BMC default settings.

## 3.6 Event Logs

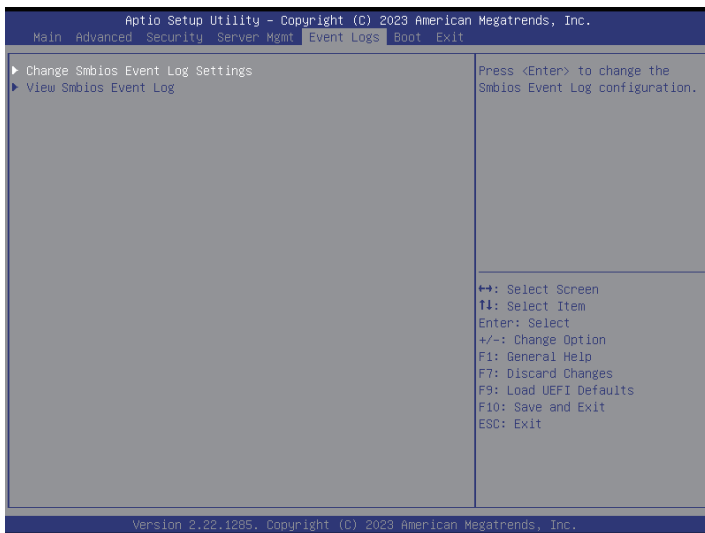

### Change Smbios Event Log Settings

Select item to configure the Smbios Event Log Settings.

When entering, the items as below are displayed:

#### **Smbios Event Log**

Use this item to enable or disable all features of the SMBIOS Event Logging during system boot.

#### **Erase Event Log**

The options include [No], [Yes, Next reset] and [Yes, Every reset]. If Yes is selected, all logged events will be erased.

#### **When Log is Full**

Use this item to choose options for reactions to a full Smbios Event Log. The options include [Do Nothing] and [Erase Immediately].

#### **Log System Boot Event**

Choose option to enable/disable logging of System boot event.

#### **MECI (Multiple Event Count Increment)**

Use this item to enter the increment value for the multiple event counter. The valid range is from 1 to 255.

#### **METW (Multiple Event Time Window)**

Use this item to specify the number of minutes which must pass between duplicate log entries which utilize a multiple-event counter. The value ranges from 0 to 99 minutes.

### **Log EFI Status Code**

Enable or disable the logging of EFI Status Codes as OEM reserved type E0 (if not already converted to legacy).

### **Convert EFI Status Codes to Standard Smbios Type**

Enable or disable the converting of EFI Status Codes to Standard Smbios Types (Not all may be translated).

### **View Smbios Event Log**

Press <Enter> to view the Smbios Event Log records.



*All values changed here do not take effect until computer is restarted.*

## 3.7 Boot Screen

In this section, it will display the available devices the system for user to configure the boot settings and the boot priority.

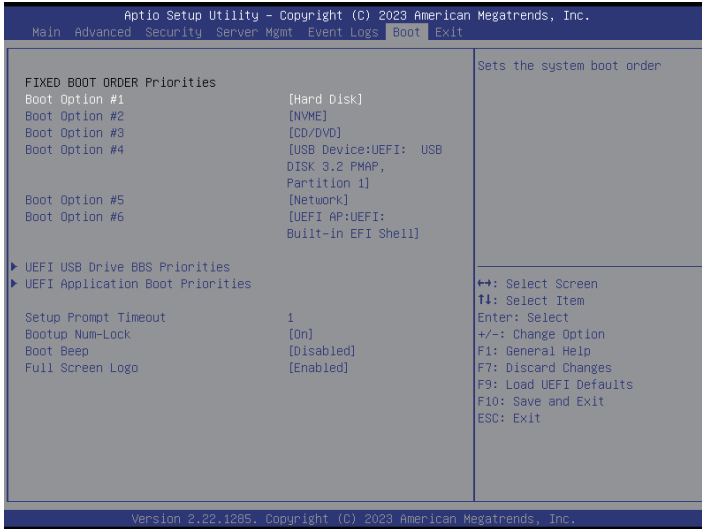

### Boot Option #1/#2/#3/#4/#5/#6

Use this item to set the system boot order.

### UEFI USB Drive BBS Priorities

Specifies the Boot Device Priority sequence from available UEFI USB Drives.

### UEFI Application Boot Priorities

Specifies the Boot Device Priority sequence from available UEFI Application.

### Setup Prompt Timeout

Configure the number of seconds to wait for the UEFI setup utility.

### Bootup Num-Lock

If this item is set to [On], it will automatically activate the Numeric Lock function after boot-up.

### Boot Beep

Select whether the Boot Beep should be turned on or off when the system boots up. Please note that a buzzer is needed.

---

## Full Screen Logo

Use this item to enable or disable OEM Logo. The default value is [Enabled].

## 3.8 Exit Screen

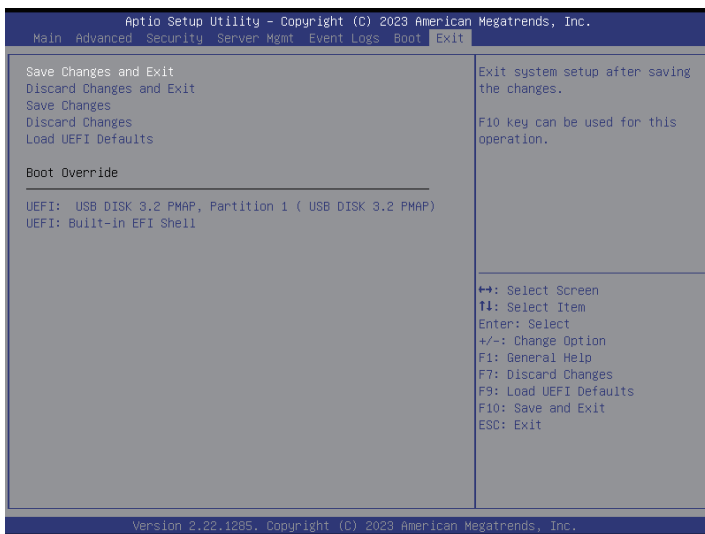

### Save Changes and Exit

When selecting this option, the following message “Save configuration changes and exit setup?” will pop-out. Press <F10> key or select [Yes] to save the changes and exit the UEFI SETUP UTILITY.

### Discard Changes and Exit

When selecting this option, the following message “Discard changes and exit setup?” will pop-out. Press <ESC> key or select [Yes] to exit the UEFI SETUP UTILITY without saving any changes.

### Save Changes

When selecting this option, the following message “Save changes?” will pop-out. Press <F7> key or select [Yes] to save all changes.

### Discard Changes

When selecting this option, the following message “Discard changes?” will pop-out. Press <F7> key or select [Yes] to discard all changes.

### Load UEFI Defaults

Load UEFI default values for all the setup questions. F9 key can be used for this operation.

# Chapter 4 Software Support

After all the hardware has been installed, go to our official website at <http://www.ASRockRack.com> and make sure if there are any new updates of the BIOS / BMC firmware for the motherboard.

## 4.1 Download and Install Operating System

This motherboard supports various Microsoft® Windows® Server / Linux compliant operating systems. Please download the operating system from the OS manufacturer. Please refer to the OS documentation for more instructions.

*\*Please download the Intel® SATA Floppy Image driver from the ASRock Rack's website ([www.asrockrack.com](http://www.asrockrack.com)) to the USB drive while installing OS in SATA RAID mode.*

## 4.2 Download and Install Software Drivers

This motherboard supports various Microsoft® Windows® compliant drivers. Please download the required drivers from our website at <http://www.ASRockRack.com>.

To download necessary drivers, go to the product page, click on the "Download" tab, choose the operating system, and select the required driver to download.

## 4.3 Contact Information

Contact ASRock Rack or want to know more about ASRock Rack, welcome to visit ASRock Rack's website at <http://www.ASRockRack.com>; or contact the dealer for further information.



# Chapter 5 Troubleshooting

## 5.1 Troubleshooting Procedures

Follow the procedures below to troubleshoot the system.



*Always unplug the power cord before adding, removing or changing any hardware components. Failure to do so may cause physical injuries to personal and damages to motherboard components.*

1. Disconnect the power cable and check whether the PWR LED is off.
2. Unplug all cables, connectors and remove all add-on cards from the motherboard. Make sure that the jumpers are set to default settings.
3. Confirm that there are no short circuits between the motherboard and the chassis.
4. Install a CPU and fan on the motherboard, then connect the chassis speaker and power LED.

### **If there is no power...**

1. Confirm that there are no short circuits between the motherboard and the chassis.
2. Make sure that the jumpers are set to default settings.
3. Check the settings of the 115V/230V switch on the power supply.
4. Verify if the battery on the motherboard provides ~3VDC. Install a new battery if it does not.

### **If there is no video...**

1. Try replugging the monitor cables and power cord.
2. Check for memory errors.

### **If there are memory errors...**

1. Verify that the DIMM modules are properly seated in the slots.
2. Use recommended DDR5 RDIMM and RDIMM-3DS.
3. If having installed more than one DIMM modules, they should be identical with the same brand, speed, size and chip-type.
4. Try inserting different DIMM modules into different slots to identify faulty ones.
5. Check the settings of the 115V/230V switch on the power supply.

---

**Unable to save system setup configurations...**

1. Verify if the battery on the motherboard provides ~3VDC. Install a new battery if it does not.
2. Confirm whether the power supply provides adequate and stable power.

**Other problems...**

1. Try searching keywords related to the problem on ASRock Rack's FAQ page:  
<http://www.asrockrack.com/support>

## 5.2 Technical Support Procedures

If having tried the troubleshooting procedures mentioned above and the problems are still unsolved, please contact ASRock Rack's technical support with the following information:

1. Contact information
2. Model name, BIOS version and problem type.
3. System configuration.
4. Problem description.

Contact ASRock Rack's technical support at:

<http://www.asrockrack.com/support/tsd.asp>

## 5.3 Returning Merchandise for Service

For warranty service, the receipt or a copy of the invoice marked with the date of purchase is required. By calling the vendor or going to the RMA website (<http://event.asrockrack.com/tsd.asp>) to obtain a Returned Merchandise Authorization (RMA) number.

The RMA number should be displayed on the outside of the shipping carton which is mailed prepaid or hand-carried when returning the motherboard to the manufacturer. Shipping and handling charges will be applied for all orders that must be mailed when service is complete.

This warranty does not cover damages incurred in shipping or from failure due to alteration, misuse, abuse or improper maintenance of products.

Contact the distributor first for any product related problems during the warranty period.

## **Contact Information**

Contact ASRock Rack or want to know more about ASRock Rack, you're welcome to visit ASRock Rack's website at <http://www.asrockrack.com>; or contact the dealer for further information. For technical questions, please submit a support request form at <https://event.asrockrack.com/tsd.asp>

### **ASRock Rack Incorporation**

e-mail: [ASRockRack\\_sales@asrockrack.com](mailto:ASRockRack_sales@asrockrack.com)

### **ASRock Rack EUROPE B.V.**

Bijsterhuizen 11-11  
6546 AR Nijmegen  
The Netherlands  
Phone: +31-24-345-44-33

### **ASRock Rack America, Inc.**

13848 Magnolia Ave, Chino, CA91710 U.S.A.  
Phone: +1-909-590-8308  
Fax: +1-909-590-1026