



GENOAD8X-2T/BCM

User Manual

Version 1.0

Published February 2023

Copyright©2023 ASRock Rack INC. All rights reserved.

Version 1.0

Published February 2023

Copyright©2023 ASRock Rack INC. All rights reserved.

Copyright Notice:

No part of this documentation may be reproduced, transcribed, transmitted, or translated in any language, in any form or by any means, except duplication of documentation by the purchaser for backup purpose, without written consent of ASRock Rack Inc.

Products and corporate names appearing in this documentation may or may not be registered trademarks or copyrights of their respective companies, and are used only for identification or explanation and to the owners' benefit, without intent to infringe.

Disclaimer:

Specifications and information contained in this documentation are furnished for informational use only and subject to change without notice, and should not be construed as a commitment by ASRock Rack. ASRock Rack assumes no responsibility for any errors or omissions that may appear in this documentation.

With respect to the contents of this documentation, ASRock Rack does not provide warranty of any kind, either expressed or implied, including but not limited to the implied warranties or conditions of merchantability or fitness for a particular purpose.

In no event shall ASRock Rack, its directors, officers, employees, or agents be liable for any indirect, special, incidental, or consequential damages (including damages for loss of profits, loss of business, loss of data, interruption of business and the like), even if ASRock Rack has been advised of the possibility of such damages arising from any defect or error in the documentation or product.



This device complies with Part 15 of the FCC Rules. Operation is subject to the following two conditions:

- (1) this device may not cause harmful interference, and
- (2) this device must accept any interference received, including interference that may cause undesired operation.

This equipment has been tested and found to comply with the limits for a Class B digital device, pursuant to part 15 of the FCC Rules. These limits are designed to provide reasonable protection against harmful interference in a residential installation. This equipment generates, uses and can radiate radio frequency energy and, if not installed and used in accordance with the instructions, may cause harmful interference to radio communications. However, there is no guarantee that interference will not occur in a particular installation.

If this equipment does cause harmful interference to radio or television reception, which can be determined by turning the equipment off and on, the user is encouraged to try to correct the interference by one or more of the following measures:

- Reorient or relocate the receiving antenna.
- Increase the separation between the equipment and receiver.
- Connect the equipment into an outlet on a circuit different from that to which the receiver is connected.
- Consult the dealer or an experienced radio/TV technician for help.

CALIFORNIA, USA ONLY

The Lithium battery adopted on this motherboard contains Perchlorate, a toxic substance controlled in Perchlorate Best Management Practices (BMP) regulations passed by the California Legislature. When you discard the Lithium battery in California, USA, please follow the related regulations in advance.

“Perchlorate Material-special handling may apply, see www.dtsc.ca.gov/hazardouswaste/perchlorate”

AUSTRALIA ONLY

Our goods come with guarantees that cannot be excluded under the Australian Consumer Law. You are entitled to a replacement or refund for a major failure and compensation for any other reasonably foreseeable loss or damage caused by our goods. You are also entitled to have the goods repaired or replaced if the goods fail to be of acceptable quality and the failure does not amount to a major failure. If you require assistance please call ASRock Rack Tel : +886-2-55599600 ext.123 (Standard International call charges apply)



ASRock Rack INC. hereby declares that this device is in compliance with the essential requirements and other relevant provisions of related UKCA Directives. Full text of UKCA declaration of conformity is available at: <http://www.asrockrack.com>



ASRock Rack INC. hereby declares that this device is in compliance with the essential requirements and other relevant provisions of related Directives. Full text of EU declaration of conformity is available at: <http://www.asrockrack.com>

ASRock Rack follows the green design concept to design and manufacture our products, and makes sure that each stage of the product life cycle of ASRock Rack product is in line with global environmental regulations. In addition, ASRock Rack disclose the relevant information based on regulation requirements.

Please refer to <https://www.asrockrack.com/general/about.asp?cat=Responsibility> for information disclosure based on regulation requirements ASRock Rack is complied with:



DO NOT throw the motherboard in municipal waste. This product has been designed to enable proper reuse of parts and recycling. This symbol of the crossed out wheeled bin indicates that the product (electrical and electronic equipment) should not be placed in municipal waste. Check local regulations for disposal of electronic products.

Chapter 1 Introduction

Thank you for purchasing ASRock Rack **GENOAD8X-2T/BCM** motherboard, a reliable motherboard produced under ASRock Rack's consistently stringent quality control. It delivers excellent performance with robust design conforming to ASRock Rack's commitment to quality and endurance.

In this manual, chapter 1 and 2 contains introduction of the motherboard and step-by-step guide to the hardware installation. Chapter 3 and 4 contains the configuration guide to BIOS setup and information of the Software Support.



Because the motherboard specifications and the BIOS software might be updated, the content of this manual will be subject to change without notice. In case any modifications of this manual occur, the updated version will be available on ASRock Rack website without further notice. You may find the latest memory and CPU support lists on ASRock Rack website as well. ASRock Rack's Website: www.ASRockRack.com

*If you require technical support related to this motherboard, please visit our website for specific information about the model you are using.
<http://www.asrockrack.com/support/>*

1.1 Package Contents

- ASRock Rack GENOAD8X-2T/BCM Motherboard
(EEB-like Form Factor: 12.63-in x 13-in)
- Quick Installation Guide
- 1 x MCIO X4 to 4 SATA +8P Cable (63cm)
- 2 x Screws for M.2 Sockets



If any items are missing or appear damaged, contact your authorized dealer.

1.2 Specifications

GENOAD8X-2T/BCM	
MB Physical Status	
Form Factor	EEB like
Dimension	12.63" x 13" (320.8 x 330.2mm)
Processor System	
CPU	Supports AMD EPYC 9004 processors
Socket	1 Socket SP5 (LGA-6096)
Thermal Design Power (TDP)	400W
Chipset	System on Chip
System Memory	
Supported DIMM Quantity	8 DIMM slots (1DPC)
Supported Type	Supports DDR5 288-pin RDIMM, RDIMM-3DS
Max. Capacity per DIMM	RDIMM: 64GB (2R) RDIMM-3DS: 512GB (2S8Rx4)
Max. Frequency	4800MHz
Voltage	1.1V
Note	<i>Memory capacity, frequency, and voltage support is to be validated</i>
PCIe Expansion Slot (Slot7 close to CPU)	
Slot 7	PCIe5.0 x8
Slot 6	PCIe5.0 / CXL1.1 x16
Slot 5	PCIe5.0 x16
Slot 4	PCIe5.0 / CXL1.1 x16
Slot 3	PCIe5.0 x16
Slot 2	PCIe5.0 / CXL1.1 x16
Slot 1	PCIe5.0 x16
Slot 0	PCIe5.0 / CXL1.1 x16
Note	* SLOT7 shares lanes with MCIO1 and MCIO2. MCIO1 and MCIO2 will be disabled when SLOT7 is populated * SLOT1 shares lanes with MCIO4 and M2_2. SLOT1 auto-switch to PCIe5.0 x8 when MCIO4 and M2_2 are populated
Other PCIe Expansion Connectors	
M.2	M2_1 (PCIe5.0 x4 or 4 SATA 6Gb/s), supports 22110/2280 form factor M2_2 (PCIe5.0 x4), supports 22110/2280 form factor
MCIO	3 MCIO (PCIe5.0 x4 or 4 SATA 6Gb/s) 1 MCIO (PCIe5.0 x4)
SATA/SAS Storage	
CPU Built-in Storage	AMD EPYC 9004 (16 SATA 6Gb/s): 3 MCIO, 4 SATA via optional M2U2_HD_G4 M.2 device
Ethernet	
Additional Ethernet Controller	Broadcom BCM57416: 2 RJ45 (10GbE)

USB	
Controller/Hub	AMD EPYC 9004
Connectors/Headers	External: 2 Type-A (USB3.2 Gen1) Internal: 1 header (19-pin, 2 USB3.2 Gen1)
Graphics	
Controller	ASPEED AST2600: 1 DB15 (VGA)
Security	
TPM	1 (13-pin, SPI)
Rear I/O	
UID Button/LED	1 UID button w/ LED
VGA Port	1 DB15 (VGA)
Serial Port	1 DB9 (COM)
USB	2 Type-A (USB3.2 Gen1)
RJ45	2 RJ45 (10GbE), 1 dedicated IPMI
Hardware Monitor	
Temperature	CPU, MB, TR1 Temperature sensing
Fan	CPU/Rear/Front Fan Tachomete CPU Quiet Fan (Allow Chassis Fan Speed Auto-Adjust by CPU Temperature) CPU/Rear/Front Fan Multi-Speed Control
Voltage	VCORE,VCCSA,VCCM,3V, 5V, 12V, +1.05V_PCH_ AUX,+BAT, 3VSB, 5VSB,VCCIO,+2.5V_VPP
Server Management	
BMC Controller	ASPEED AST2600: IPMI2.0 with iKVM and vMedia support
IPMI Dedicated GLAN	1 Realtek RTL8211F for dedicated management GLAN
System BIOS	
Type	AMI UEFI BIOS; 256 Mb (32MB) SPI Flash ROM
Features	ASRock Rack Instant Flash, ACPI 6.4 and above compliance wake up events, SMBIOS 3.5.0 and above, Plug and Play(PnP)
Other Internal Connectors/Headers	
PSU Connector	1 (24-pin, ATX main power), 3 (8-pin, ATX 12V)
Auxiliary Panel Header	1 (18-pin): chassis intrusion, system fault LED, LAN1/LAN2 activity LED, locate, SMBus
System Panel Header	1 (9-pin): power switch, reset switch, system power LED, HDD activity LED
NMI Header	1
COM Header	1
VGA Header	1
Speaker Header	1 (4-pin)
Fan Header	8 (6-pin)
Thermal Sensor Header	1

TPM Header	1 (13-pin, SPI)
SMBus	1
PMBus	1
IPMB Header	1
Clear CMOS	1 (contact pads)
Others	1 RDS1 header [BTO], 1 SlimSAS (PCIe2.0 x1) for Redstone-Next [BTO]
LED Indicators	
Standby Power LED	1 (5VSB)
80 debug port LED	1
Fan Fail LED	8
BMC Heartbeat LED	1
Support OS	
OS	<p>Microsoft® Windows®:</p> <ul style="list-style-type: none"> - Server 2016 (64bit) - Server 2019 (64bit) - Server 2022 (64 bit) <p>Linux®:</p> <ul style="list-style-type: none"> - RedHat Enterprise Linux Server 8.3 (64 bit) / 8.4 (64 bit) - CentOS 8.3 (64 bit) / 8.4 (64 bit) - SUSE SLES 15.2 (64 bit) / 12.5 (64 bit) - Ubuntu 21.04 (64 bit) / 20.04.3 (64 bit) / 18.04.5 (64 bit) <p>Hypervisor:</p> <ul style="list-style-type: none"> - VMWare® ESXi 6.7.0 u3 / vSphere 6.7.0 u3 - VMWare® ESXi 7.0 U1 / vSphere 7.0 U1 - VMWare® ESXi 7.0 U2a / vSphere 7.0 U2b - CITRIX Hypervisor 8.2.0 <p><i>*Please refer to our website for the latest OS support list.</i></p>
Environment	
Temperature	<p>Operation temperature: 10°C ~ 35°C (50 - 95 degF)</p> <p>Non operation temperature: -40°C ~ 70°C (-40 - 158degF)</p>
Humidity	Non operation humidity: 20% ~ 90% (Non condensing)

NOTE: Please refer to our website for the latest specifications.



This motherboard supports Wake from on Board LAN. To use this function, please make sure that the "Wake on Magic Packet from power off state" is enabled in Device Manager > Intel® Ethernet Connection > Power Management. And the "PCI Devices Power On" is enabled in UEFI SETUP UTILITY > Advanced > ACPI Configuration. After that, onboard LAN1&2 can wake up S5 under OS.



If you install Intel® LAN utility or Marvell SATA utility, this motherboard may fail Windows® Hardware Quality Lab (WHQL) certification tests. If you install the drivers only, it will pass the WHQL tests.

1.3 Unique Features

ASRock Rack Instant Flash is a BIOS flash utility embedded in Flash ROM. This convenient BIOS update tool allows you to update system BIOS without entering operating systems first like MS-DOS or Windows. With this utility, you can press the <F6> key during the POST or the <F2> key to enter into the BIOS setup menu to access ASRock Rack Instant Flash. Just launch this tool and save the new BIOS file to your USB flash drive, floppy disk or hard drive, then you can update your BIOS only in a few clicks without preparing an additional floppy diskette or other complicated flash utility. Please be noted that the USB flash drive or hard drive must use FAT32/16/12 file system.

No.	Description
1	2 x 288-pin DDR5 DIMM Slots (DDR5_G1, DDR5_I1)*
2	2 x 288-pin DDR5 DIMM Slots (DDR5_H1, DDR5_K1)*
3	AMD Socket SP5 (SM-LGA-6096) (CPU1)
4	ATX Power Connector (ATXPWR1)
5	ATX 12V Power Connector (ATX12V2)
6	ATX 12V Power Connector (ATX12V1)
7	ATX 12V Power Connector (ATX12V3)
8	PWM Configuration Header (PWM_CFG1)
9	2 x 288-pin DDR5 DIMM Slots (DDR5_A1, DDR5_C1)*
10	System Fan Connector (FAN1)
11	Mini Cool Edge IO x8 Connector (MCIO3)
12	System Fan Connector (FAN2)
13	2 x 288-pin DDR5 DIMM Slots (DDR5_B1, DDR5_E1)*
14	USB 3.2 Gen1 Header (USB3_3_4)
15	Mini Cool Edge IO x8 Connector (MCIO4)
16	PCIe Signal Source Selection Jumper (PCIE7_MCIO2_SW)
17	System Fan Connector (FAN3)
18	System Fan Connector (FAN4)
19	System Fan Connector (FAN5)
20	System Fan Connector (FAN6)
21	Clear CMOS Pad (CLRMOS1)
22	Mini Cool Edge IO x8 Connector (MCIO1)
23	Mini Cool Edge IO x8 Connector (MCIO2)
24	Graphics 12V Power Connector (GFX_12V1)
25	SATA SGPIO Connector (SATA_SGPIO1)
26	System Fan Connector (FAN7)
27	SATA SGPIO Connector (SATA_SGPIO2)
28	System Fan Connector (FAN8)
29	COM Port Header (COM2)
30	PSU SMBus Header (PSU_SMB1)
31	System Panel Header (PANEL1)
32	Auxiliary Panel Header (AUX_PANEL1)
33	Speaker Header (SPEAKER1)
34	Thermal Sensor Header (TR1)

No.	Description
35	Backplane PCI Express Hot-Plug Connector (CPU1_HSBP1)
36	Non Maskable Interrupt Button (NMI_BTN1)
37	Intelligent Platform Management Bus Header (IPMB1)
38	BMC SMBus Header (BMC_SMB1)
39	M.2 Socket (M2_1) (Type 2280/22110)
40	M.2 Socket (M2_2) (Type 2280/22110)
41	PCI Express 5.0 x16 Slot (PCIE0)
42	PCI Express 5.0 x16 Slot (PCIE1)
43	PCI Express 5.0 x16 Slot (PCIE2)
44	PCI Express 5.0 x16 Slot (PCIE3)
45	PCI Express 5.0 x16 Slot (PCIE4)
46	PCI Express 5.0 x16 Slot (PCIE5)
47	PCI Express 5.0 x16 Slot (PCIE6)
48	PCI Express 5.0 x8 Slot (PCIE7)
49	SPI TPM Header (TPM_BIOS_PH1)
50	Front VGA Header (FRNT_VGA1)

* For DIMM installation and configuration instructions, please see p.19 (Installation of Memory Modules (DIMM)) for more details.

1.5 Onboard LED Indicators

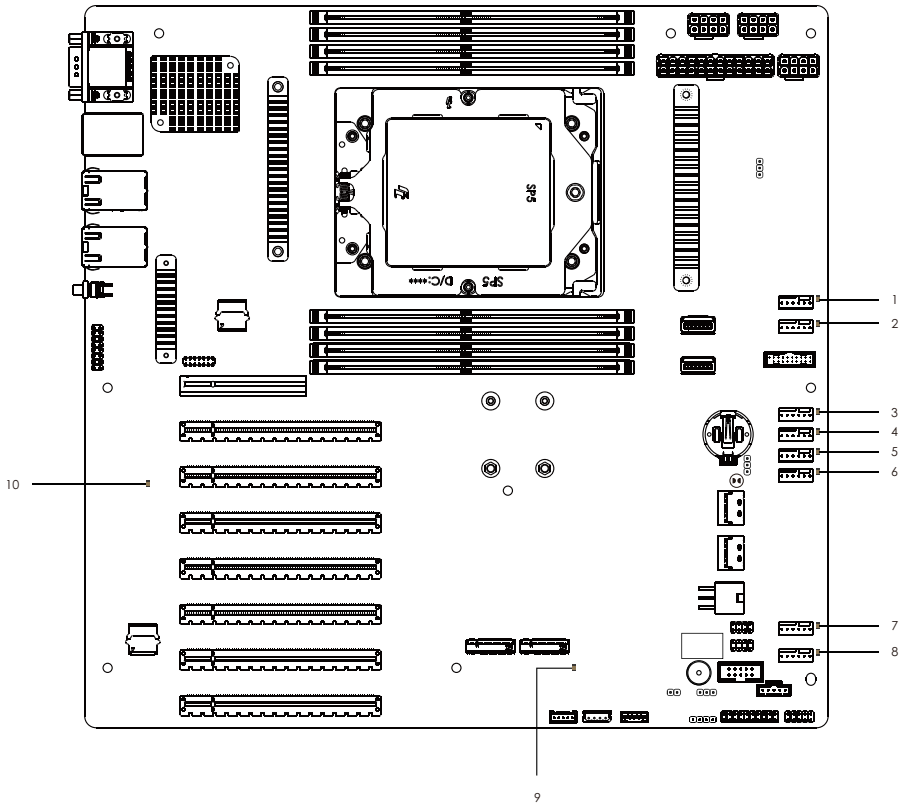

No.	Item	Status	Description
1	LED_FAN1	Red	FAN1 failed
2	LED_FAN2	Red	FAN2 failed
3	LED_FAN3	Red	FAN3 failed
4	LED_FAN4	Red	FAN4 failed
5	LED_FAN5	Red	FAN5 failed
6	LED_FAN6	Red	FAN6 failed
7	LED_FAN7	Red	FAN7 failed
8	LED_FAN8	Red	FAN8 failed
9	SB_PWR1	Green	STB PWR ready
10	BMC_LED1	Green	BMC heartbeat LED

1.6 I/O Panel

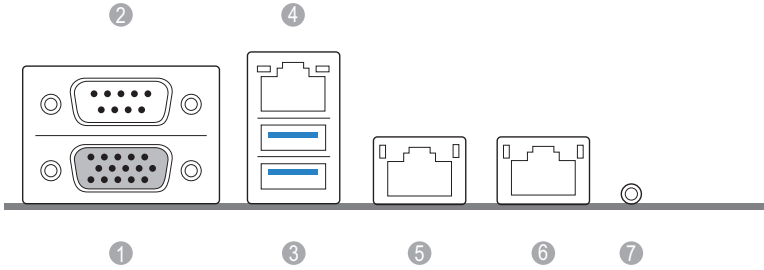

No.	Description	No.	Description
1	Serial Port (COM1)	5	10G LAN RJ-45 Port (LAN1)**
2	VGA Port (VGA)	6	10G LAN RJ-45 Port (LAN2)**
3	USB 3.2 Gen1 Ports (USB3_1_2)	7	UID Switch (UID1)
4	IPMI LAN Header (IPMI_LAN1)*		

LAN Port LED Indications

*There are two LEDs next to the IPMI LAN port. Please refer to the table below for the LAN port LED indications.

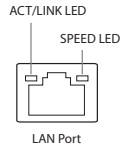

IPMI LAN Port LED Indications

Activity / Link LED		Speed LED	
Status	Description	Status	Description
Off	No Link	Off	10Mbps connection or no link
Blinking Yellow	Data Activity	Orange	100Mbps connection
On	Link	Green	1Gbps connection

**There are two LEDs on each 10G LAN port. Please refer to the table below for the LAN port LED indications.

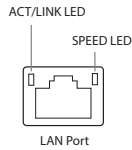

10G LAN Port LED Indications

Activity / Link LED		Speed LED	
Status	Description	Status	Description
Off	No Link	Off	100Mbps connection or no link
Blinking Yellow	Data Activity	Orange	1Gbps connection
On	Link	Green	10Gbps connection

Chapter 2 Installation

This is an EEB-like form factor (12.63" x 13", 32.08 x 33.02cm) motherboard. Before you install the motherboard, study the configuration of your chassis to ensure that the motherboard fits into it.



Make sure to unplug the power cord before installing or removing the motherboard. Failure to do so may cause physical injuries to you and damages to motherboard components.

2.1 Screw Holes

Place screws into the holes indicated by circles to secure the motherboard to the chassis.



Do not over-tighten the screws! Doing so may damage the motherboard.

2.2 Pre-installation Precautions

Take note of the following precautions before you install motherboard components or change any motherboard settings.

1. Unplug the power cord from the wall socket before touching any components.
2. To avoid damaging the motherboard's components due to static electricity, NEVER place your motherboard directly on the carpet or the like. Also remember to use a grounded wrist strap or touch a safety grounded object before you handle the components.
3. Hold components by the edges and do not touch the ICs.
4. Whenever you uninstall any component, place it on a grounded anti-static pad or in the bag that comes with the component.
5. When placing screws into the screw holes to secure the motherboard to the chassis, please do not over-tighten the screws! Doing so may damage the motherboard.



Before you install or remove any component, ensure that the power is switched off or the power cord is detached from the power supply. Failure to do so may cause severe damage to the motherboard, peripherals, and/or components.

2.3 Installing the CPU



1. Before you insert the CPU into the socket, please check if the PnP cap is on the socket, if the CPU surface is unclean, or if there are any bent pins in the socket. Do not force to insert the CPU into the socket if above situation is found. Otherwise, the CPU will be seriously damaged.
2. Unplug all power cables before installing the CPU.

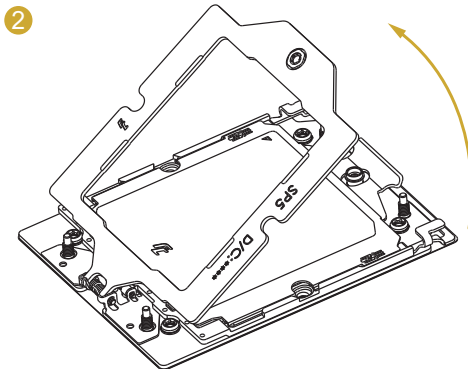
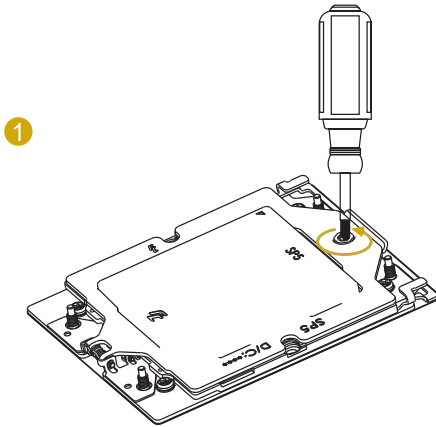

3

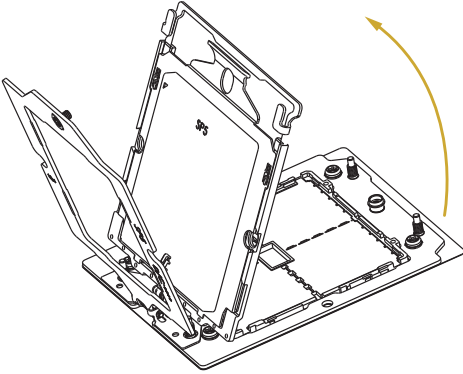

4

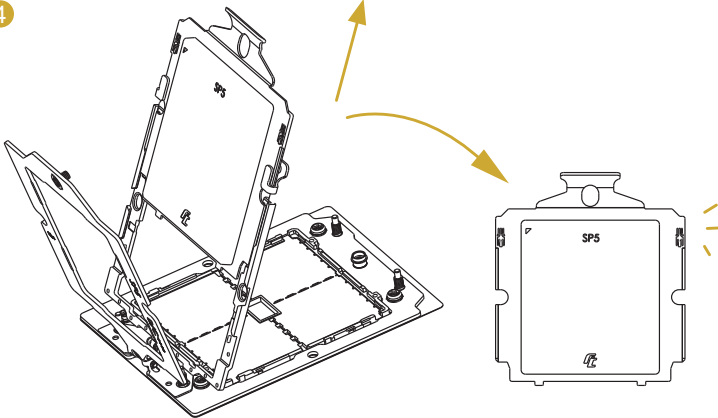

5

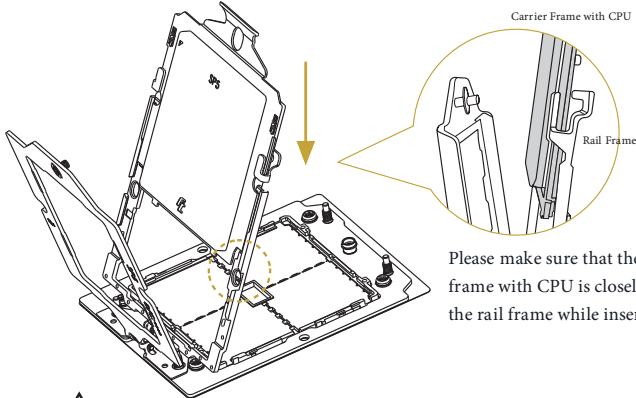

Please make sure that the carrier frame with CPU is closely attached to the rail frame while inserting it.



Install the carrier frame with CPU. Don't separate them.

6

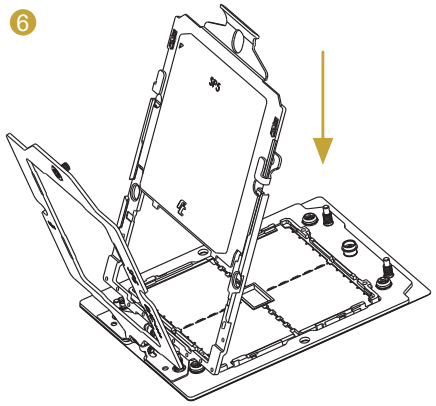

7

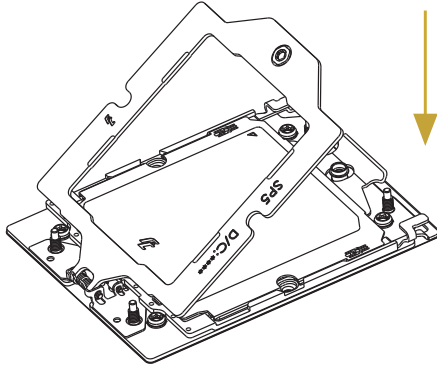

8

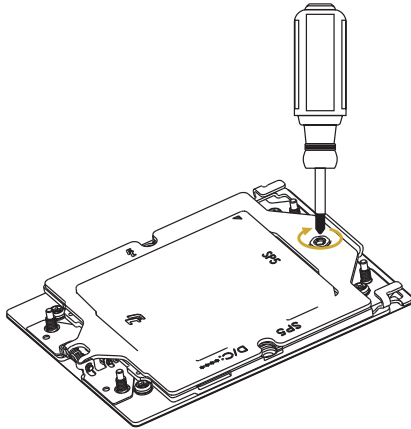

9

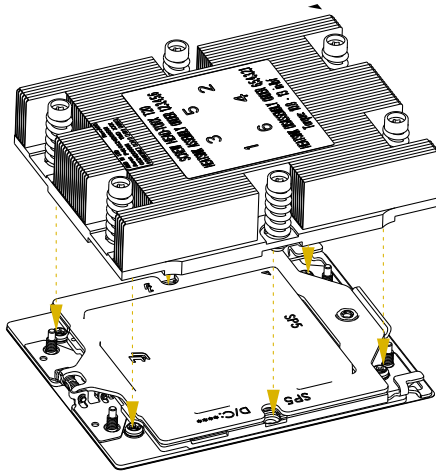

10

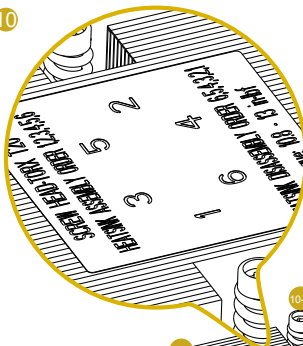

Set your torque wrench to 1.54 in.-lb.
One fourth a turn each time.

Tighten the screws in a sequential order
1 > 2 > 3 > 4 > 5 > 6.
Loosen the screws in a reverse order.

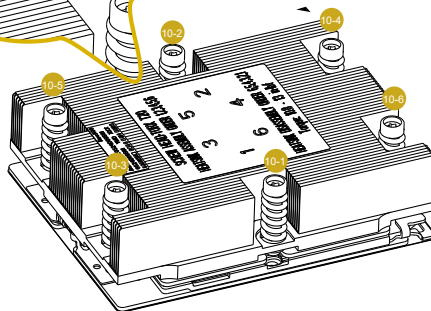

2.4 Installation of Memory Modules (DIMM)

This motherboard provides eight 288-pin DDR5 (Double Data Rate 5) DIMM slots in two groups, and supports Eight Channel Memory Technology.



1. For Eight channel configuration, you always need to install identical (the same brand, speed, size and chip-type) DDR5 DIMM groups.
2. Eight Channel Memory Technology is enabled only when 8 or 16 memory modules are installed.
3. It is not allowed to install a DDR, DDR2, DDR3 or DDR4 memory module into a DDR5 slot; otherwise, this motherboard and DIMM may be damaged.

Recommended Memory Configurations

	CPU1							
	A1	B1	C1	E1	G1	H1	I1	K1
1 DIMM	V							
2 DIMMS	V				V			
4 DIMMS	V		V		V		V	
8 DIMMS	V	V	V	V	V	V	V	V

The symbol V indicates the slot is populated.

1

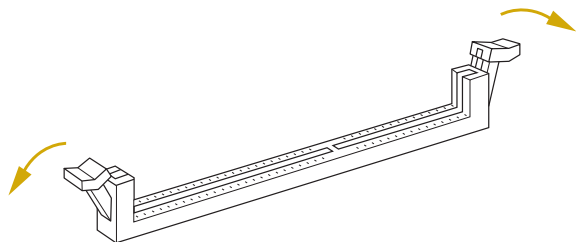

2

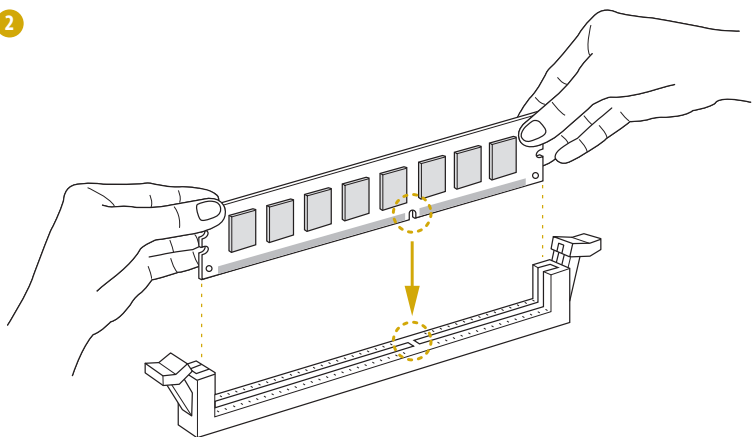

3

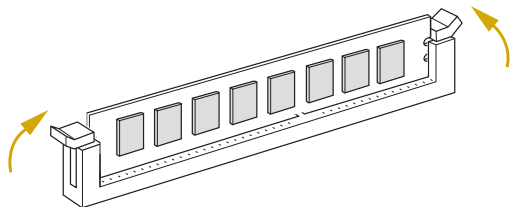

2.5 Expansion Slots (PCI Express Slots)

There are eight PCI Express slots on this motherboard.

PCIe slots:

PCIE0 (PCIe 5.0 x16 slot, from CPU1) is used for PCI Express x16 lane width cards.

PCIE1 (PCIe 5.0 x16 slot, from CPU1) is used for PCI Express x16 lane width cards.

PCIE2 (PCIe 5.0 x16 slot, from CPU1) is used for PCI Express x16 lane width cards.

PCIE3 (PCIe 5.0 x16 slot, from CPU1) is used for PCI Express x16 lane width cards.

PCIE4 (PCIe 5.0 x16 slot, from CPU1) is used for PCI Express x16 lane width cards.

PCIE5 (PCIe 5.0 x16 slot, from CPU1) is used for PCI Express x16 lane width cards.

PCIE6 (PCIe 5.0 x16 slot, from CPU1) is used for PCI Express x16 lane width cards.

PCIE7 (PCIe 5.0 x8 slot, from CPU1) is used for PCI Express x8 lane width cards.

Slot	Generation	Mechanical	Electrical	Source
PCIE0	5.0	x16	x16	CPU1
PCIE1	5.0	x16	x16	CPU1
PCIE2	5.0	x16	x16	CPU1
PCIE3	5.0	x16	x16	CPU1
PCIE4	5.0	x16	x16	CPU1
PCIE5	5.0	x16	x16	CPU1
PCIE6	5.0	x16	x16	CPU1
PCIE7	5.0	x8	x8	CPU1

Installing an expansion card

- Step 1. Before installing an expansion card, please make sure that the power supply is switched off or the power cord is unplugged. Please read the documentation of the expansion card and make necessary hardware settings for the card before you start the installation.
- Step 2. Remove the system unit cover (if your motherboard is already installed in a chassis).
- Step 3. Remove the bracket facing the slot that you intend to use. Keep the screws for later use.
- Step 4. Align the card connector with the slot and press firmly until the card is completely seated on the slot.
- Step 5. Fasten the card to the chassis with screws.
- Step 6. Replace the system cover.



1. SLOT7 shares lanes with MCIO1 and MCIO2. MCIO1 and MCIO2 will be disabled when SLOT7 is populated.
2. SLOT1 shares lanes with MCIO4 and M2_2. SLOT1 auto-switch to PCIe5.0 x8 when MCIO4 and M2_2 are populated.

2.6 Jumper Setup

The illustration shows how jumpers are setup. When the jumper cap is placed on the pins, the jumper is “Short”. If no jumper cap is placed on the pins, the jumper is “Open”. The illustration shows a 3-pin jumper whose pin1 and pin2 are “Short” when a jumper cap is placed on these 2 pins.

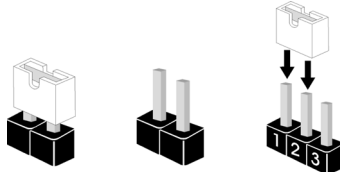

PCIE Signal Source Selection Jumper

(3-pin PCIE7_MCIO2_SW)
(see p.6, No. 16)



PCIE7(x4) + MCIO2(x4)



PCIE7(x8) (Default)



1. SLOT7 shares lanes with MCIO1 and MCIO2. MCIO1 and MCIO2 will be disabled when SLOT7 is populated.
2. SLOT1 shares lanes with MCIO4 and M2_2. SLOT1 auto-switch to PCIe5.0 x8 when MCIO4 and M2_2 are populated.

2.7 Onboard Headers and Connectors



Onboard headers and connectors are NOT jumpers. Do NOT place jumper caps over these headers and connectors. Placing jumper caps over the headers and connectors will cause permanent damage to the motherboard.

System Panel Header
(9-pin PANEL1)
(see p.6, No. 31)

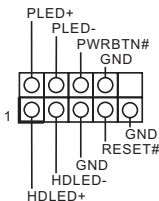

Connect the power switch, reset switch and system status indicator on the chassis to this header according to the pin assignments. Particularly note the positive and negative pins before connecting the cables.



PWRBTN (Power Switch):

Connect to the power switch on the chassis front panel. You may configure the way to turn off your system using the power switch.

RESET (Reset Switch):

Connect to the reset switch on the chassis front panel. Press the reset switch to restart the computer if the computer freezes and fails to perform a normal restart.

PLED (System Power LED):

Connect to the power status indicator on the chassis front panel. The LED is on when the system is operating. The LED is off when the system is in S4 sleep state or powered off (S5).

HDLED (Hard Drive Activity LED):

Connect to the hard drive activity LED on the chassis front panel. The LED is on when the hard drive is reading or writing data.

The front panel design may differ by chassis. A front panel module mainly consists of power switch, reset switch, power LED, hard drive activity LED, speaker and etc. When connecting your chassis front panel module to this header, make sure the wire assignments and the pin assignments are matched correctly.

Auxiliary Panel Header
(18-pin AUX_PANEL1)
(see p.6, No. 32)

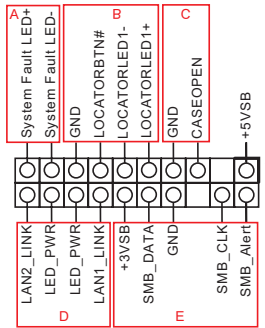

This header supports multiple functions on the front panel, including front panel SMB, internet status indicator.



A. System Fault LED (2-pin LOCATOR)
This header is for the Fault LED on the system.

B. Locator LED (4-pin LOCATOR)
This header is for the locator switch and LED on the front panel.

C. Chassis intrusion pin (2-pin CHASSIS)
This header is provided for host computer chassis with chassis intrusion detection designs. In addition, it must also work with external detection equipment, such as a chassis intrusion detection sensor or a microswitch. When this function is activated, if any chassis component movement occurs, the sensor will immediately detect it and send a signal to this header, and the system will then record this chassis intrusion event. The default setting is set to the CASEOPEN and GND pin; this function is off.

D. Internet status indicator (2-pin LAN1_LED, LAN2_LED)
These two 2-pin headers allow you to use the Gigabit internet indicator cable to connect to the LAN status indicator. When this indicator flickers, it means that the internet is properly connected.

E. Front panel SMBus connecting pin (6-1 pin FPSMB)
This header allows you to connect SMBus (System Management Bus) equipment. It can be used for communication between peripheral equipment in the system, which has slower transmission rates, and power management equipment.

Front VGA Header
(15-pin FRNT_VGA1)
(see p.6, No.50)

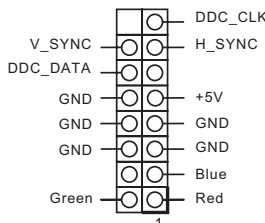

Please connect either end of VGA_2X8 cable to VGA header.

USB 3.2 Gen1 Header:
(19-pin USB3_3_4)
(see p.6, No. 14)



Besides two default USB 3.2 Gen1 ports on the I/O panel, there is one USB 3.2 Gen1 header on this motherboard. This USB 3.2 Gen1 header can support two USB 3.2 Gen1 ports.

PWM Configuration Header
(3-pin PWM_CFG1)
(see p.6, No. 8)

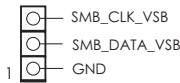

The header is used for PWM configurations.

Non Maskable Interrupt Button Header
(2-pin NMI_BTN1)
(see p.6, No. 36)



Please connect a NMI device to this header.

PSU SMBus Header
(PSU_SMB1)
(see p.6, No. 30)

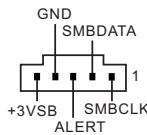

PSU SMBus monitors the status of the power supply, fan and system temperature.

BMC SMB Header
(5-pin BMC_SMB1)
(see p.6, No. 38)

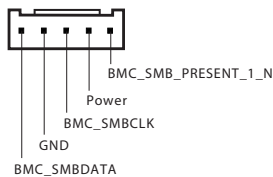

The header is used for the SMBUS devices.

Backplane PCI Express
Hot-Plug Connector
(5-pin CPU1_HSBP1)
(see p.6, No. 35)

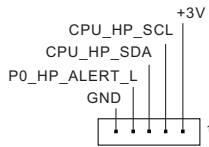

The header is used for the hot plug feature of HDDs on the backplane.

System Fan Connectors
(6-pin FAN1)

(see p.6, No. 10)

(6-pin FAN2)

(see p.6, No. 12)

(6-pin FAN3)

(see p.6, No. 17)

(6-pin FAN4)

(see p.6, No. 18)

(6-pin FAN5)

(see p.6, No. 19)

(6-pin FAN6)

(see p.6, No. 20)

(6-pin FAN7)

(see p.6, No. 26)

(6-pin FAN8)

(see p.6, No. 28)

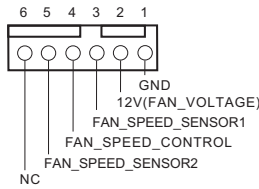

Please connect fan cables to the fan connectors and match the black wire to the ground pin. All fans support Fan Control.

SPI TPM Header
(13-pin TPM_BIOS_PH1)
(see p.6, No. 49)

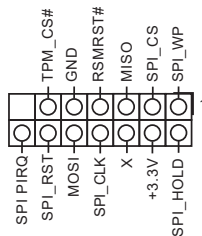

This connector supports SPI Trusted Platform Module (TPM) system, which can securely store keys, digital certificates, passwords, and data. A TPM system also helps enhance network security, protects digital identities, and ensures platform integrity.

ATX Power Connector
(24-pin ATXPWR1)
(see p.6, No. 4)

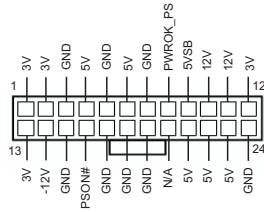

This motherboard provides a 24-pin ATX power connector. To use a 20-pin ATX power supply, please plug it along Pin 1 and Pin 13.

ATX Power Connectors
(8-pin ATX12V1)
(see p.6, No. 6)
(8-pin ATX12V2)
(see p.6, No. 5)
(8-pin ATX12V3)
(see p.6, No. 7)

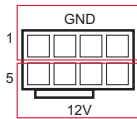

This motherboard provides three ATX power connectors.

Graphics 12V Power Connector
(6-pin GFX_12V1)
(see p.6, No. 24)

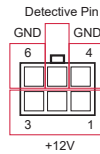

This motherboard provides a 6-pin Graphics 12V power connector. * Install the PSU's power cable to this connector when 4 graphics cards are installed.

Intelligent Platform Management Bus Header
(4-pin IPMB1)
(see p.6, No. 37)

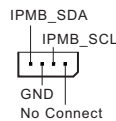

This 4-pin connector is used to provide a cabled baseboard or front panel connection for value added features and 3rd-party add-in cards, such as Emergency Management cards, that provide management features using the IPMB.

Serial General Purpose Input/Output Headers
(7-pin SATA_SGPIO1)
(see p.6, No. 25)
(7-pin SATA_SGPIO2)
(see p.6, No. 27)

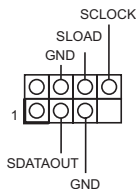

These headers support Serial Link interface for onboard SATA connections.

Serial Port Header
(9-pin COM2)
(see p.6, No. 29)

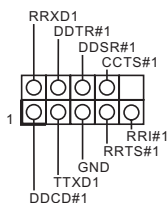

This COM header supports a serial port module.

Thermal Sensor Header
(3-pin TR1)
(see p.6, No. 34)

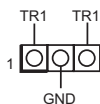

Please connect the thermal sensor cable to either pin 1-2 or pin 2-3 and the other end to the device which you wish to monitor its temperature.

Clear CMOS Pad
(CLRCMOS1)
(see p.6, No. 21)



This allows you to clear the data in CMOS. To clear CMOS, take out the CMOS battery and short the Clear CMOS Pad.

MCIO x8 Connectors
(MCIO1)
(see p.6, No. 22)
(MCIO2)
(see p.6, No. 23)
(MCIO3)
(see p.6, No. 11)
(MCIO4)
(see p.6, No. 15)

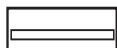

These connectors are used for the PCIE devices.

Chassis Speaker Header
(4-pin SPEAKER1)
(see p.6, No. 33)



Please connect the chassis speaker to this header.

2.8 Dr. Debug

Dr. Debug is used to provide code information, which makes troubleshooting even easier. Please see the diagrams below for reading the Dr. Debug codes.

Code	Description
0x10	PEI_CORE_STARTED
0x11	PEI_CAR_CPU_INIT
0x15	PEI_CAR_NB_INIT
0x19	PEI_CAR_SB_INIT
0x31	PEI_MEMORY_INSTALLED
0x32	PEI_CPU_INIT
0x33	PEI_CPU_CACHE_INIT
0x34	PEI_CPU_AP_INIT
0x35	PEI_CPU_BSP_SELECT
0x36	PEI_CPU_SMM_INIT
0x37	PEI_MEM_NB_INIT
0x3B	PEI_MEM_SB_INIT
0x4F	PEI_DXE_IPL_STARTED
0x60	DXE_CORE_STARTED
0x61	DXE_NVRAM_INIT
0x62	DXE_SBRUN_INIT

0x63	DXE_CPU_INIT
0x68	DXE_NB_HB_INIT
0x69	DXE_NB_INIT
0x6A	DXE_NB_SMM_INIT
0x70	DXE_SB_INIT
0x71	DXE_SB_SMM_INIT
0x72	DXE_SB_DEVICES_INIT
0x78	DXE_ACPI_INIT
0x79	DXE_CSM_INIT
0x90	DXE_BDS_STARTED
0x91	DXE_BDS_CONNECT_DRIVERS
0x92	DXE_PCI_BUS_BEGIN
0x93	DXE_PCI_BUS_HPC_INIT
0x94	DXE_PCI_BUS_ENUM
0x95	DXE_PCI_BUS_REQUEST_RESOURCES
0x96	DXE_PCI_BUS_ASSIGN_RESOURCES
0x97	DXE_CON_OUT_CONNECT
0x98	DXE_CON_IN_CONNECT

0x99	DXE_SIO_INIT
0x9A	DXE_USB_BEGIN
0x9B	DXE_USB_RESET
0x9C	DXE_USB_DETECT
0x9D	DXE_USB_ENABLE
0xA0	DXE_IDE_BEGIN
0xA1	DXE_IDE_RESET
0xA2	DXE_IDE_DETECT
0xA3	DXE_IDE_ENABLE
0xA4	DXE_SCSI_BEGIN
0xA5	DXE_SCSI_RESET
0xA6	DXE_SCSI_DETECT
0xA7	DXE_SCSI_ENABLE
0xA8	DXE_SETUP_VERIFYING_PASSWORD
0xA9	DXE_SETUP_START
0xAB	DXE_SETUP_INPUT_WAIT
0xAD	DXE_READY_TO_BOOT
0xAE	DXE_LEGACY_BOOT

0xAF	DXE_EXIT_BOOT_SERVICES
0xB0	RT_SET_VIRTUAL_ADDRESS_MAP_BEGIN
0xB1	RT_SET_VIRTUAL_ADDRESS_MAP_END
0xB2	DXE_LEGACY_OPROM_INIT
0xB3	DXE_RESET_SYSTEM
0xB4	DXE_USB_HOTPLUG
0xB5	DXE_PCI_BUS_HOTPLUG
0xB6	DXE_NVRAM_CLEANUP
0xB7	DXE_CONFIGURATION_RESET
0xF0	PEI_RECOVERY_AUTO
0xF1	PEI_RECOVERY_USER
0xF2	PEI_RECOVERY_STARTED
0xF3	PEI_RECOVERY_CAPSULE_FOUND
0xF4	PEI_RECOVERY_CAPSULE_LOADED
0xE0	PEI_S3_STARTED
0xE1	PEI_S3_BOOT_SCRIPT
0xE2	PEI_S3_VIDEO_REPOST

0xE3	PEI_S3_OS_WAKE
0x50	PEI_MEMORY_INVALID_TYPE
0x53	PEI_MEMORY_NOT_DETECTED
0x55	PEI_MEMORY_NOT_INSTALLED
0x57	PEI_CPU_MISMATCH
0x58	PEI_CPU_SELF_TEST_FAILED
0x59	PEI_CPU_NO_MICROCODE
0x5A	PEI_CPU_ERROR
0x5B	PEI_RESET_NOT_AVAILABLE
0xD0	DXE_CPU_ERROR
0xD1	DXE_NB_ERROR
0xD2	DXE_SB_ERROR
0xD3	DXE_ARCH_PROTOCOL_NOT_AVAILABLE
0xD4	DXE_PCI_BUS_OUT_OF_RESOURCES
0xD5	DXE_LEGACY_OPROM_NO_SPACE
0xD6	DXE_NO_CON_OUT
0xD7	DXE_NO_CON_IN

0xD8	DXE_INVALID_PASSWORD
0xD9	DXE_BOOT_OPTION_LOAD_ERROR
0xDA	DXE_BOOT_OPTION_FAILED
0xDB	DXE_FLASH_UPDATE_FAILED
0xDC	DXE_RESET_NOT_AVAILABLE
0xE8	PEI_MEMORY_S3_RESUME_FAILED
0xE9	PEI_S3_RESUME_PPI_NOT_FOUND
0xEA	PEI_S3_BOOT_SCRIPT_ERROR
0xEB	PEI_S3_OS_WAKE_ERROR

2.9 Identification purpose LED/Switch

With the UID button, You are able to locate the server you're working on from behind a rack of servers.

Unit Identification
purpose LED/Switch
(UID1)



When the UID button on the front or rear panel is pressed, the front/rear UID blue LED indicator will be turned on. Press the UID button again to turn off the indicator.

2.10 M.2 SSD Module Installation Guide

The M.2 Socket (M2_1/M2_2, Key M) supports type 2280/22110 M.2 PCI Express module up to Gen4 x4 (16GT/s x4).

Installing the M.2 SSD Module

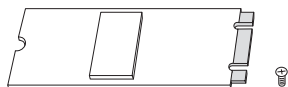

Step 1

Prepare a M.2_SSD module and the screw.

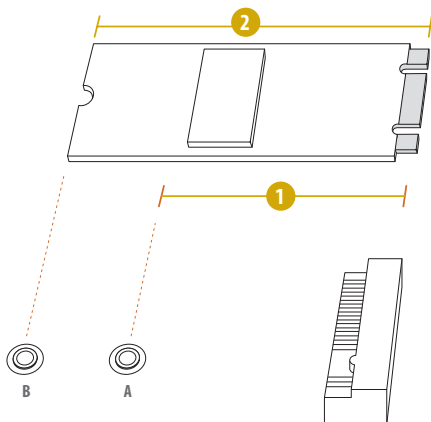

Step 2

Depending on the PCB type and length of your M.2 SSD module, find the corresponding nut location to be used.

No.	1	2
Nut Location	A	B
PCB Length	8cm	11cm
Module Type	Type2280	Type 22110

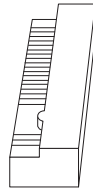
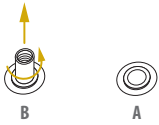
**Step 3**

Move the standoff based on the module type and length. Skip Step 3 and 4 and go straight to Step 5 if you are going to use the default nut. Otherwise, release the standoff by hand.

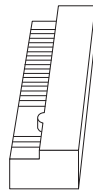
**Step 4**

Peel off the yellow protective film on the nut to be used. Hand tighten the standoff into the desired nut location on the motherboard.

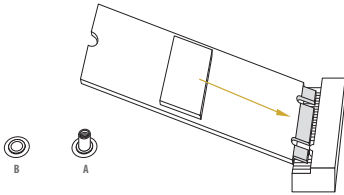
**Step 5**

Align and gently insert the M.2 SSD module into the M.2 slot. Please be aware that the M.2 SSD module only fits in one orientation.

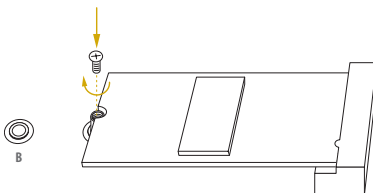
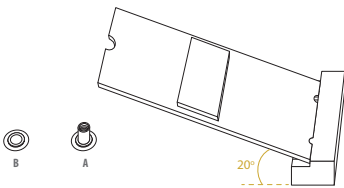
**Step 6**

Tighten the screw with a screwdriver to secure the module into place. Please do not overtighten the screw as this might damage the module.

2.11 Dual LAN and Teaming Operation Guide

Dual LAN with Teaming enabled on this motherboard allows two single connections to act as one single connection for twice the transmission bandwidth, making data transmission more effective and improving the quality of transmission of distant images. Fault tolerance on the dual LAN network prevents network downtime by transferring the workload from a failed port to a working port.



The speed of transmission is subject to the actual network environment or status even with Teaming enabled.

Before setting up Teaming, please make sure whether your Switch (or Router) supports Teaming (IEEE 802.3ad Link Aggregation). You can specify a preferred adapter in Intel PROSet. Under normal conditions, the Primary adapter handles all non-TCP/IP traffic. The Secondary adapter will receive fallback traffic if the primary fails. If the Preferred Primary adapter fails, but is later restored to an active status, control is automatically switched back to the Preferred Primary adapter.

Step 1

From **Device Manager**, open the properties of a team.

Step 2

Click the **Settings** tab.

Step 3

Click the **Modify Team** button.

Step 4

Select the adapter you want to be the primary adapter and click the **Set Primary** button.

If you do not specify a preferred primary adapter, the software will choose an adapter of the highest capability (model and speed) to act as the default primary. If a failover occurs, another adapter becomes the primary. The adapter will, however, rejoin the team as a non-primary.